

HDR-TG1/TG1E/TG3E

SERVICE MANUAL

LEVEL 2

Ver. 1.3 2009.06

Revision History

Revised-1

Replacement of the previously issued
SERVICE MANUAL 9-852-295-32
with this manual.



Photo: HDR-TG1

US Model
Canadian Model
AEP Model
UK Model
North European Model
E Model
Australian Model
Hong Kong Model
Chinese Model
Korea Model
Tourist Model
Japanese Model

Link

SPECIFICATIONS	DISASSEMBLY	SCHEMATIC DIAGRAMS
MODEL INFORMATION TABLE	BLOCK DIAGRAMS	PRINTED WIRING BOARDS
SERVICE NOTE	FRAME SCHEMATIC DIAGRAM	REPAIR PARTS LIST

• Precaution on Replacing the VC-522 Board

The components identified by mark Δ or dotted line with mark Δ are critical for safety. Replace only with part number specified.

Les composants identifiés par une marque Δ sont critiques pour la sécurité. Ne les remplacer que par une pièce portant le numéro spécifié.



DIGITAL HD VIDEO CAMERA RECORDER

SONY®



HANDYCAM

AVCHD



HDMI

SPECIFICATIONS

System

Video compression format: AVCHD (HD)/MPEG2 (SD)/JPEG (Still images)
Audio compression format: Dolby Digital 2/5.1ch
Dolby Digital 5.1 Creator
Video signal: PAL color, CCIR standards
1080/50i specification
Recording format: Movie (HD): AVCHD 1080/50i
Movie (SD): MPEG2-PS
Still image: Exif Ver.2.2*¹
Image device: 3.6 mm (1/5 type) CMOS sensor
Recording pixels (still image, 4:3):
Max. 4.0 mega (2 304 × 1 728) pixels*²
Gross: Approx. 2 360 000 pixels
Effective (movie, 16:9): Approx. 1 430 000 pixels
Effective (still image, 16:9): Approx. 1 490 000 pixels
Effective (still image, 4:3): Approx. 1 990 000 pixels
Lens: Carl Zeiss Vario-Tessar
10 × (Optical), 20 ×, 120 × (Digital)
Focal length: F1.8 ~ 2.3
f=3.2 ~ 32.0 mm (5/32 ~ 1 5/16 in.)
When converted to a 35 mm still camera
For movies*³: 43 ~ 507 mm (1 3/4 ~ 20 in.) (16:9)
For still images: 38 ~ 380 mm (1 1/2 ~ 15 in.) (4:3)
Color temperature: [AUTO], [ONE PUSH], [INDOOR] (3 200 K), [OUTDOOR] (5 800 K)
Minimum illumination: 5 lx (lux) ([AUTO SLW SHUTTR] [ON], Shutter speed 1/25 sec)

*¹ "Exif" is a file format for still images, established by the JEITA (Japan Electronics and Information Technology Industries Association). Files in this format can have additional information such as your camcorder's setting information at the time of recording.

*² The unique pixel array of Sony's ClearVid CMOS sensor and image processing system (BIONZ) allows still image resolution equivalent to the sizes described.

*³ The focal length figures are actual figures resulting from wide angle pixel readout.

Input/Output connectors

A/V Remote Connector: Component/video and audio output jack
HDMI OUT jack: HDMI mini Connector

LCD screen

Image: 6.7 cm (2.7 type, aspect ratio 16:9)
Total dot number: 211 200 (960 × 220)

General

Power requirements: DC 6.8 V/7.2 V (battery pack)
DC 8.4 V (AC Adaptor)
Average power consumption: During camera recording using the LCD with normal brightness:
HD: 3.3 W
SD: 2.7 W
Operating temperature: 0 °C to + 40 °C (32 °F to 104 °F)
Storage temperature: -20 °C to + 60 °C (-4 °F to + 140 °F)
Dimensions (approx.): 32 × 119 × 63 mm (1 5/16 × 4 3/4 × 2 1/2 in.) (w/h/d) including the projecting parts
32 × 119 × 63 mm (1 5/16 × 4 3/4 × 2 1/2 in.) (w/h/d) including the projecting parts, and the supplied rechargeable battery pack attached
Mass (approx.): 240 g (8 oz) main unit only
300 g (10 oz) including the supplied rechargeable battery pack, and a "Memory Stick PRO Duo"

Handycam Station DCRA-C230

Input/Output connectors

A/V OUT jack: Component/video and audio output jack
USB jack: mini-B
(HDR-TG3E: output only)

Dedicated USB Terminal Adaptor

Input/Output connectors

USB jack: mini-B
(HDR-TG3E: output only)

AC Adaptor AC-L200/L200B

Power requirements: AC 100 V - 240 V, 50/60 Hz
Current consumption: 0.35 - 0.18 A
Power consumption: 18 W
Output voltage: DC 8.4 V*
Operating temperature: 0 °C to + 40 °C (32 °F to 104 °F)
Storage temperature: -20 °C to + 60 °C (-4 °F to + 140 °F)
Dimensions (approx.): 48 × 29 × 81 mm (1 15/16 × 1 3/16 × 3 1/4 in.) (w/h/d) excluding the projecting parts
Mass (approx.): 170 g (6.0 oz) excluding the power cord (mains lead)

* See the label on the AC Adaptor for other specifications.

Rechargeable battery pack NP-FH50

Maximum output voltage: DC 8.4 V
Output voltage: DC 6.8 V
Capacity: 6.1 Wh (900 mAh)
Type: Li-ion

Design and specifications are subject to change without notice.

- Manufactured under license from Dolby Laboratories.



HANDYCAM

AVCHD



HDMI

SPECIFICATIONS

System

Video compression format: AVCHD (HD)/MPEG2 (SD)/JPEG (Still images)
Audio compression format: Dolby Digital 2/5.1ch
Dolby Digital 5.1 Creator
Video signal: NTSC color, EIA standards
1080/60i specification
Recording format: Movie (HD): AVCHD 1080/60i
Movie (SD): MPEG2-PS
Still image: Exif Ver.2.2*¹
Image device: 3.6 mm (1/5 type) CMOS sensor
Recording pixels (still image, 4:3):
Max. 4.0 mega (2 304 × 1 728) pixels*²
Gross: Approx. 2 360 000 pixels
Effective (movie, 16:9): Approx. 1 430 000 pixels
Effective (still image, 16:9): Approx. 1 490 000 pixels
Effective (still image, 4:3): Approx. 1 990 000 pixels
Lens: Carl Zeiss Vario-Tessar
10 × (Optical), 20 ×, 120 × (Digital)
Focal length: F1.8 ~ 2.3
f=3.2 ~ 32.0 mm (5/32 ~ 1 5/16 in.)
When converted to a 35 mm still camera
For movies*³: 43 ~ 507 mm (1 3/4 ~ 20 in.) (16:9)
For still images: 38 ~ 380 mm (1 1/2 ~ 15 in.) (4:3)
Color temperature: [AUTO], [ONE PUSH], [INDOOR] (3 200 K), [OUTDOOR] (5 800 K)
Minimum illumination: 5 lx (lux) ([AUTO SLW SHUTTR] [ON], Shutter speed 1/30 sec)

*¹ "Exif" is a file format for still images, established by the JEITA (Japan Electronics and Information Technology Industries Association). Files in this format can have additional information such as your camcorder's setting information at the time of recording.

*² The unique pixel array of Sony's ClearVid CMOS sensor and image processing system (BIONZ) allows still image resolution equivalent to the sizes described.

*³ The focal length figures are actual figures resulting from wide angle pixel readout.

Input/Output connectors

A/V Remote Connector: Component/video and audio output jack
HDMI OUT jack: HDMI mini Connector

LCD screen

Image: 6.7 cm (2.7 type, aspect ratio 16:9)
Total dot number: 211 200 (960 × 220)

General

Power requirements: DC 6.8 V/7.2 V (battery pack)
DC 8.4 V (AC Adaptor)
Average power consumption: During camera recording using the LCD with normal brightness:
HD: 3.4 W
SD: 2.7 W
Operating temperature: 0 °C to + 40 °C (32 °F to 104 °F)
Storage temperature: -20 °C to + 60 °C (-4 °F to + 140 °F)
Dimensions (approx.): 32 × 119 × 63 mm (1 5/16 × 4 3/4 × 2 1/2 in.) (w/h/d) including the projecting parts
32 × 119 × 63 mm (1 5/16 × 4 3/4 × 2 1/2 in.) (w/h/d) including the projecting parts, and the supplied rechargeable battery pack attached
Mass (approx.): 240 g (8 oz) main unit only
300 g (10 oz) including the supplied rechargeable battery pack, and a "Memory Stick PRO Duo"

Handycam Station DCRA-C230

Input/Output connectors

A/V OUT jack: Component/video and audio output jack
USB jack: mini-B

Dedicated USB Terminal Adaptor

Input/Output connectors

USB jack: mini-B

AC Adaptor AC-L200/L200B

Power requirements: AC 100 V - 240 V, 50/60 Hz
Current consumption: 0.35 - 0.18 A
Power consumption: 18 W
Output voltage: DC 8.4 V*
Operating temperature: 0 °C to + 40 °C (32 °F to 104 °F)
Storage temperature: -20 °C to + 60 °C (-4 °F to + 140 °F)
Dimensions (approx.): 48 × 29 × 81 mm (1 15/16 × 1 3/16 × 3 1/4 in.) (w/h/d) excluding the projecting parts
Mass (approx.): 170 g (6.0 oz) excluding the power cord (mains lead)

* See the label on the AC Adaptor for other specifications.

Rechargeable battery pack NP-FH50

Maximum output voltage: DC 8.4 V
Output voltage: DC 6.8 V
Capacity: 6.1 Wh (900 mAh)
Type: Li-ion

Design and specifications are subject to change without notice.

- Manufactured under license from Dolby Laboratories.



HANDYCAM

AVCHD



HDMI

概略仕様

システム

映像圧縮方式: AVCHD (HD)/MPEG2 (SD)/JPEG
(静止画)

音声圧縮方式: Dolby Digital2/5.1ch
ドルビーデジタル5.1クリエーター搭載

映像信号: NTSCカラー、EIA標準方式
1080/60i方式

動画記録方式: 動画HD: AVCHD 1080/60i
動画SD: MPEG2-PS

静止画記録方式: Exif Ver.2.2*1

撮像素子: 3.6 mm (1/5型) CMOSセンサー
記録画素数: 静止画時最大400万画素相当*2
(2 304 × 1 728) (4:3時)
総画素数: 約236万画素
動画時有効画素数 (16:9): 約143万画素
静止画時有効画素数 (16:9): 約149万画素
静止画時有効画素数 (4:3): 約199万画素

ズームレンズ: カール ツァイス バリオテッサ
10倍 (光学)、20倍、120倍 (デジタル)
F1.8~2.3
f=3.2~32.0 mm
35mmカメラ換算では
動画撮影時*3:
43~507 mm (16:9)
静止画撮影時:
38~380 mm (4:3)

色温度切り換え: [オート]、[ワンプッシュ]、[屋内]
(3 200 K)、[屋外] (5 800 K)

最低被写体照度: 5 lx (ルクス) ([オートスロシャッタ]
[入]、[シャッタースピード] 1/30秒)

*1 (社)電子情報技術産業協会 (JEITA)にて
制定された、撮影情報などの付帯情報を追
加することができる静止画用のファイル
フォーマット。

*2 ソニー独自のクリアビッドCMOSセン
サーの画素配列と画像処理システム
BIONZにより、静止画は表記の記録サイ
ズを実現しています。

*3 広角画素読み出しによる実動作値

入出力端子

A/Vリモート端子: コンポーネント、映像音声出力兼
用端子

HDMI OUT端子: HDMIミニコネクタ

液晶画面

画面サイズ: 6.7 cm (2.7型、アスペクト比16:9)

総ドット数: 211 200ドット
横960×縦220

電源部、その他

電源電圧: バッテリー端子入力 6.8 V/7.2 V
DC端子入力 8.4 V

消費電力: 液晶画面の明るさ標準:
HD 3.4 W、SD 2.7 W

動作温度: 0°C~+40°C
保存温度: -20°C~+60°C

外形寸法: 32×119×63 mm
(突起部を含む) (幅×高さ×奥行き)
32×119×63 mm
(突起部含む、付属バッテリー装着状態)
(幅×高さ×奥行き)

本体質量: 約240 g (本体のみ)

撮影時総質量: 約300 g (付属バッテリー、"メモリー
スティック PRO デュオ"含む)

ハンディカムステーション DCRA-C230

入出力端子

A/V OUT端子: コンポーネント、映像音声出力兼用端
子

USB端子: mini-B

専用USB端子アダプター

入出力端子

USB端子: mini-B

ACアダプター AC-L200/L200B

電源: AC 100 V-240 V、50/60 Hz

消費電力: 18 W

定格出力: DC 8.4 V *

動作温度: 0°C~+40°C

保存温度: -20°C~+60°C

外形寸法: 約 48×29×81 mm
(最大突起部をのぞく) (幅×高さ×奥行き)

質量: 約170 g (本体のみ)

* その他の仕様については AC アダプターのラ
ベルをご覧ください。

リチャージャブルバッテリーパック NP-FH50

最大電圧: DC 8.4 V

公称電圧: DC 6.8 V

容量: 6.1 Wh (900 mAh)

使用電池: Li-ion

本機の仕様および外観は、改良のため予告なく変
更することがありますが、ご了承ください。

• ドルビーラボラトリーズからの実施権に基づ
き製造されています。

Model information table

Model		HDR-TG1	HDR-TG1E	HDR-TG3E
Destination		US, CND, E KR, JE, J	NE, E, AUS, HK, CH, JE	AEP, UK, NE
Color system		NTSC	PAL	PAL
Data copy	CAM → PC	○	○	○
	PC → CAM	○	○	×

- Abbreviation
- AR : Argentine model
- AUS : Australian model
- BR : Brazilian model
- CH : Chinese model
- CND : Canadian model
- EE : East European model
- HK : Hong Kong model
- J : Japanese model
- JE : Tourist model
- KR : Korea model
- NE : North European model

CAUTION :

Danger of explosion if battery is incorrectly replaced.
Replace only with the same or equivalent type.

SAFETY-RELATED COMPONENT WARNING!!

COMPONENTS IDENTIFIED BY MARK \triangle OR DOTTED LINE WITH MARK \triangle ON THE SCHEMATIC DIAGRAMS AND IN THE PARTS LIST ARE CRITICAL TO SAFE OPERATION. REPLACE THESE COMPONENTS WITH SONY PARTS WHOSE PART NUMBERS APPEAR AS SHOWN IN THIS MANUAL OR IN SUPPLEMENTS PUBLISHED BY SONY.

ATTENTION AU COMPOSANT AYANT RAPPORT À LA SÉCURITÉ!

LES COMPOSANTS IDENTIFIÉS PAR UNE MARQUE \triangle SUR LES DIAGRAMMES SCHÉMATIQUES ET LA LISTE DES PIÈCES SONT CRITIQUES POUR LA SÉCURITÉ DE FONCTIONNEMENT. NE REMPLACER CES COMPOSANTS QUE PAR DES PIÈCES SONY DONT LES NUMÉROS SONT DONNÉS DANS CE MANUEL OU DANS LES SUPPLÉMENTS PUBLIÉS PAR SONY.

SAFETY CHECK-OUT

After correcting the original service problem, perform the following safety checks before releasing the set to the customer.

1. Check the area of your repair for unsoldered or poorly-soldered connections. Check the entire board surface for solder splashes and bridges.
2. Check the interboard wiring to ensure that no wires are "pinched" or contact high-wattage resistors.
3. Look for unauthorized replacement parts, particularly transistors, that were installed during a previous repair. Point them out to the customer and recommend their replacement.
4. Look for parts which, through functioning, show obvious signs of deterioration. Point them out to the customer and recommend their replacement.
5. Check the B+ voltage to see it is at the values specified.
6. Flexible Circuit Board Repairing
 - Keep the temperature of the soldering iron around 270°C during repairing.
 - Do not touch the soldering iron on the same conductor of the circuit board (within 3 times).
 - Be careful not to apply force on the conductor when soldering or unsoldering.

Unleaded solder

Boards requiring use of unleaded solder are printed with the lead-free mark (LF) indicating the solder contains no lead.

(Caution: Some printed circuit boards may not come printed with the lead free mark due to their particular size.)

 : LEAD FREE MARK

Unleaded solder has the following characteristics.

- Unleaded solder melts at a temperature about 40°C higher than ordinary solder.
Ordinary soldering irons can be used but the iron tip has to be applied to the solder joint for a slightly longer time.
Soldering irons using a temperature regulator should be set to about 350°C.
Caution: The printed pattern (copper foil) may peel away if the heated tip is applied for too long, so be careful!
- Strong viscosity
Unleaded solder is more viscous (sticky, less prone to flow) than ordinary solder so use caution not to let solder bridges occur such as on IC pins, etc.
- Usable with ordinary solder
It is best to use only unleaded solder but unleaded solder may also be added to ordinary solder.

注意

電池の交換は、正しく行わないと破裂する恐れがあります。電池を交換する場合には必ず同じ型名の電池又は同等品と交換してください。

サービス、点検時には次のことにご注意下さい。

1. 注意事項をお守りください。
サービスのとき特に注意を要する箇所については、キャビネット、シャーシ、部品などにラベルや捺印で注意事項を表示しています。これらの注意書き及び取扱説明書等の注意事項を必ずお守り下さい。
2. 指定部品のご使用を
セットの部品は難燃性や耐電圧など安全上の特性を持ったものとなっています。従って交換部品は、使用されていたものと同じ特性の部品を使用して下さい。特に回路図、部品表に△印で指定されている安全上重要な部品は必ず指定のものをご使用下さい。
3. 部品の取付けや配線の引きまわしはもとどおり
安全上、チューブやテープなどの絶縁材料を使用したり、プリント基板から浮かして取付けた部品があります。また内部配線は引きまわしやクランパによって発熱部品や高圧部品に接近しないよう配慮されていますので、これらは必ずもとどおりして下さい。
4. サービス後は安全点検を
サービスのために取外したネジ、部品、配線がもとどおりになっているか、またサービスした箇所の周辺を劣化させてしまったところがないかなどを点検し、安全性が確保されていることを確認して下さい。
5. チップ部品交換時の注意
 - 取外した部品は再使用しないで下さい。
 - タンタルコンデンサのマイナス側は熱に弱いため交換時は注意して下さい。
6. フレキシブルプリント基板の取扱いについて
 - コテ先温度を270℃前後にして行なって下さい。
 - 同一パターンに何度もコテ先を当てないで下さい。(3回以内)
 - パターンに力が加わらないよう注意して下さい。
7. 無鉛半田について
無鉛半田を使用している基板には、無鉛 (Lead Free) を意味するレッドフリーマークがプリントされています。
(注意：基板サイズによっては、無鉛半田を使用してもレッドフリーマークがプリントされていないものがあります)
：レッドフリーマーク
無鉛半田には、以下の特性があります。
 - 融点が従来の半田よりも約40℃高い。
従来の半田こてをそのまま使用することは可能ですが、少し長めにこてを当てる必要があります。
温度調節機能のついた半田こてを使用する場合、約350℃に設定して下さい。
注意：半田こてを長く当てすぎると、基板のパターン (銅箔) がはがれてしまうことがありますので、注意して下さい。
 - 粘性が強い
従来の半田よりも粘性が強いため、IC端子などが半田ブリッジしないように注意して下さい。
 - 従来の半田と混ぜて使用可能
無鉛半田には無鉛半田を追加するのが最適ですが、従来の半田を追加しても構いません。

1-1. POWER SUPPLY DURING REPAIRS

In this unit, about 10 seconds after power is supplied to the battery terminal using the regulated power supply (8.4 V), the power is shut off so that the unit cannot operate.

These following method is available to prevent this.

Method:

Use the AC power adaptor (AC-L200/L200B).

1-2. PRECAUTION ON REPLACING THE VC-522 BOARD

DESTINATION DATA

When you replace to the repairing board, the written destination data of repairing board also might be changed to original setting. Refer to Service Manual ADJ, and perform “DESTINATION DATA WRITE”.

USB SERIAL No.

The set is shipped with a unique ID (USB Serial No.) written in it.

This ID has not been written in a new board for service, and therefore it must be entered after the board replacement.

Refer to Service Manual ADJ, and perform “USB SERIAL No. INPUT”.

1-3. SELF-DIAGNOSIS FUNCTION

1-3-1. Self-diagnosis Function

When problems occur while the unit is operating, the self-diagnosis function starts working, and displays on the viewfinder or LCD screen what to do.

Details of the self-diagnosis functions are provided in the Instruction manual.

1-3-2. Self-diagnosis Display

When problems occur while the unit is operating, the counter of the viewfinder or LCD screen shows a 4-digit display consisting of an alphabet and numbers, which blinks at 3.2 Hz. This 5-character display indicates the “repaired by:”, “block” in which the problem occurred, and “detailed code” of the problem.

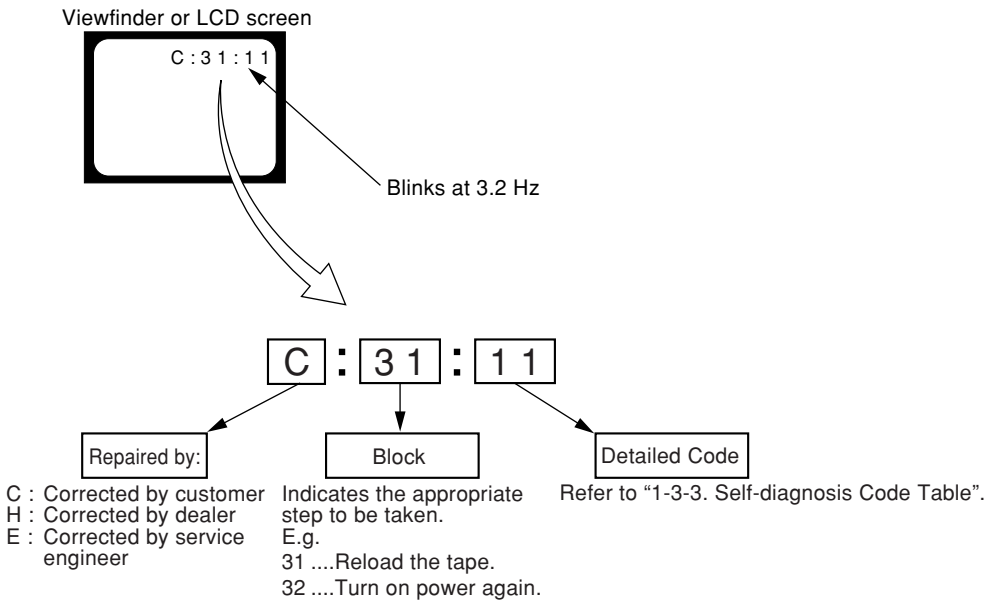

1-3-3. Self-diagnosis Code Table

Repaired by:	Self-diagnosis Code		Symptom/State	Correction
	Block Function	Detailed Code		
C	0 4	0 0	Non-standard battery is used.	Use the InfoLITHIUM battery.
C	1 3	0 1	“Memory Stick Duo” is unformatted. “Memory Stick Duo” is broken.	Format the “Memory Stick Duo”. Insert a new “Memory Stick Duo”.
C	1 3	0 2	Access error	Remove the power source. Reconnect it again and operate your camcorder again.
C	3 2	6 0	Difficult to adjust focus (Cannot initialize focus)	Retry turn the power on by the power switch. If it does not recover, check the focus MR sensor of lens block (pin ①, ② of CN5202 on the LD-235 board). If it is OK, check the focus motor drive IC (IC5201 on the LD-235 board).
E	2 0	0 0	Flash memory data are rewritten.	Make flash memory data correct value. (Note 1)
E	6 1	1 0	Zoom operations fault (Cannot initialize zoom lens.)	Inspect the lens block zoom reset sensor (pin ⑳ of CN5202 on the LD-235 board) when zooming is performed when the zoom lever is operated, and the zoom motor drive circuit (IC5201 on the LD-235 board) when zooming is not performed.
E	6 1	1 1	The abnormalities in initialization of the focus lens and the abnormalities in initialization of the zoom lens occurred simultaneously.	Check both C : 32 : 60 and E : 61 : 10 of the self-diagnosis code.
E	6 2	0 0	Handshake correction function does not work well. (With PITCH angular velocity sensor output stopped.)	Inspect PITCH/YAW angular velocity sensors (SE6602 on the SE-174 board) peripheral circuits.
E	6 2	0 1	Handshake correction function does not work well. (With YAW angular velocity sensor output stopped.)	Inspect PITCH/YAW angular velocity sensors (SE6602 on the SE-174 board) peripheral circuits.
E	9 1	0 1	Abnormality when flash is being charged.	Checking of flash unit or replacement of flash unit.
E	9 4	0 0	Fault of writing to or erasing the flash memory	Inspect the flash memory (IC2101 on the VC-522 board).

Note 1: Refer to Service manual, ADJ (“1-3. DESTINATION DATA WRITE”).

Note 2: When the lens block was replaced, execute a necessary adjustment items referring to Service Manual, ADJ.

After the adjustment, make sure with the STEADYSHOT turned ON that the steadyspot functions appropriately in the handheld operation.

1-4. PRECAUTION ON REPLACING THE CABINET (L)

1-4-1. Precaution on ordering the Cabinet (L)

The model display adopts the laser printing method. Therefore, the Cabinet (L) for replacement differs depending on the destination. As similar displays are provided, choose the suitable one for order.

Note: After replacing the Cabinet (L), the serial number for it will be changed to the one exclusive for service use. Inform a customer of the serial number change and change the serial number in the repair data.

HDR-TG1 (J)

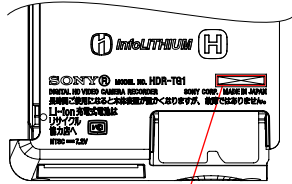

Serial No.

Part No. Description

A-1542-400-A CABINET (L (TG1-J1)), SERVICE

HDR-TG1 (US)

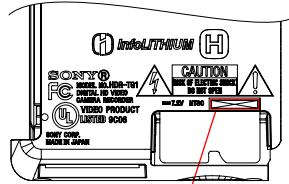

Serial No.

Part No. Description

A-1542-402-A CABINET (L (TG1-U2)), SERVICE

HDR-TG1 (CND)

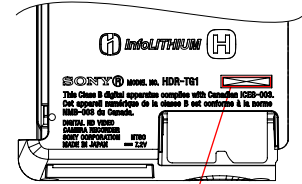

Serial No.

Part No. Description

A-1542-403-A CABINET (L (TG1-CA2)), SERVICE

HDR-TG1 (KR)

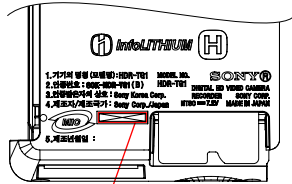

Serial No.

Part No. Description

A-1542-404-A CABINET (L (TG1-KR2)), SERVICE

HDR-TG1 (E, JE)

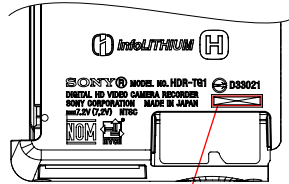

Serial No.

Part No. Description

A-1542-405-A CABINET (L (TG1-E23)), SERVICE

HDR-TG1E (NE)

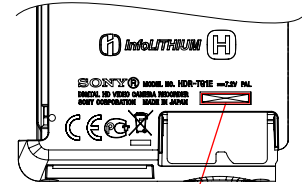

Serial No.

Part No. Description

A-1542-406-A CABINET (L (TG1-CEL)), SERVICE

HDR-TG1E (E, HK, AUS, JE)

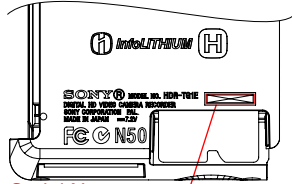

Serial No.

Part No. Description

A-1542-407-A CABINET (L (E34)), SERVICE

HDR-TG1E (CH)

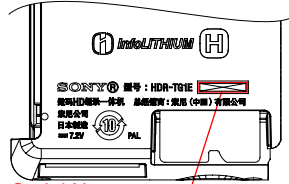

Serial No.

Part No. Description

A-1542-408-A CABINET (L (CN2)), SERVICE

HDR-TG3E (NE)

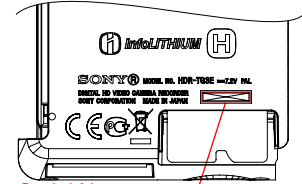

Serial No.

Part No. Description

A-1542-409-A CABINET (L (TG3-CEL)), SERVICE

HDR-TG3E (AEP, UK)

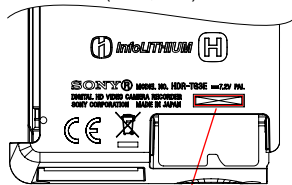

Serial No.

Part No. Description

A-1542-410-A CABINET (L (TG3-CEN)), SERVICE

1-4-2. Precaution on Replacing the Cabinet (L) for J Models

The year of manufacture on the labels should be the same as the previous Cabinet (L) (circled portions shown on the below).

Example: For the figure below, attach the “Made of 08 years” label.

* The replacement label and “inset (how to affix)” are supplied together with Cabinet (L) for service.

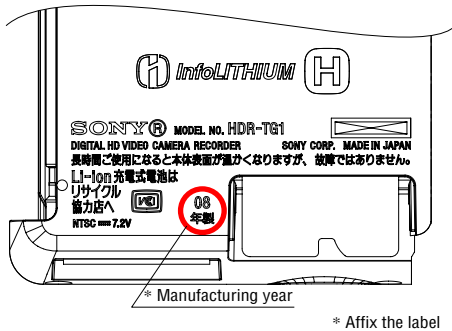

1-4-3. Precaution on Replacing the Cabinet (L) for US Models

The date of manufacture and the manufacturer on the labels should be the same as the previous Cabinet (L) (circled portions shown on the below).

Example: For the figure below, attach the “8A” and “SKD” labels.

* The replacement labels and “inset (how to affix)” are supplied together with Cabinet (L) for service.

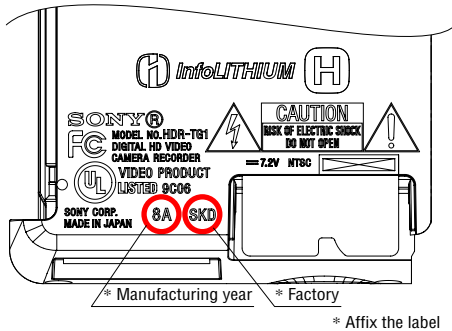

1-4-4. Precaution on Replacing the Cabinet (L) for KR Models

The date of manufacture on the labels should be the same as the previous Cabinet (L) (circled portions shown on the below).

Example: For the figure below, attach the “2008.2” label.

* The replacement label and “inset (how to affix)” are supplied together with Cabinet (L) for service.

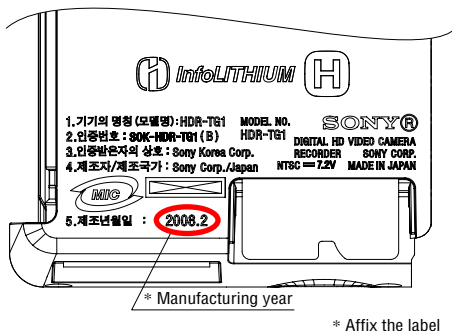

1-1. 修理時の電源供給について

本機では、安定化電源（8.4Vdc）からバッテリー端子に電源を供給した場合、約10秒後にシャットオフし、動作しなくなります。これを避けるため、下記の方法を用いてください。

方法：

DC入力端子を使用する。（ACアダプタ（AC-L200/L200B）を使用する。）

1-2. VC-522基板交換時の注意

仕向けデータ

補修用基板と交換する時、補修用基板に書かれている仕向けデータは元の設定と違っている場合があります。ADJ編を参照して、「DESTINATION DATA WRITE」を行ってください。

USBシリアルNo.

セットは、1台毎に異なる固有のID（USB Serial No.）を書き込んだ後、出荷されています。新品の補修用基板には、このIDが書き込まれていないので、基板交換後にIDを入力する必要があります。ADJ編を参照して、「USB SERIAL No. INPUT」を行ってください。

1-3. 自己診断機能

1-3-1. 自己診断機能について

本機の動作に不具合が生じたとき、自己診断機能が働き、ビューファインダまたはLCD画面に、どう処置したらよいか判断できる表示を行います。自己診断機能については取扱説明書にも掲載されています。

1-3-2. 自己診断表示

本機の動作に不具合が生じたとき、ビューファインダまたはLCD画面のカウンタ表示部分がアルファベットと数字の4桁表示になり、3.2Hzで点滅します。この5文字の表示によって対応者分類および不具合の生じたブロックの分類、不具合の詳細コードを示します。

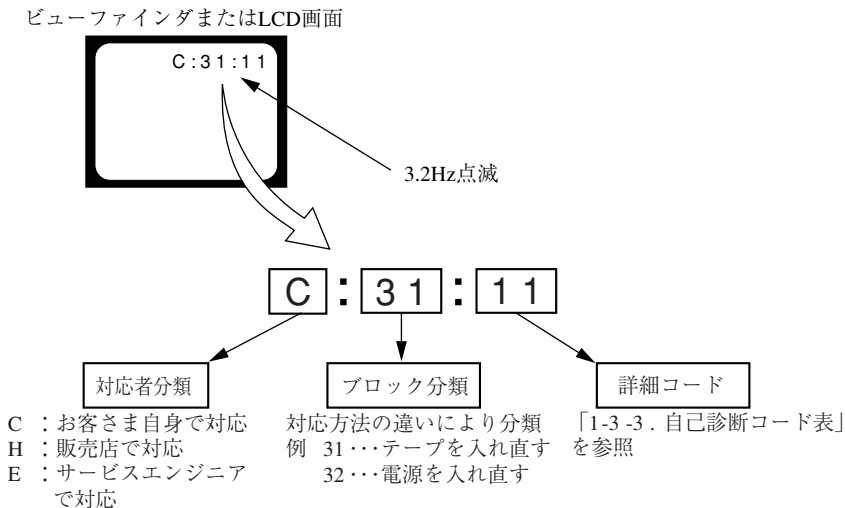

1-3-3. 自己診断コード表

自己診断コード			症状/状態	対応/方法
対応者	ブロック機能	詳細コード		
C	0 4	0 0	標準以外のバッテリーを使用している	インフォリチウムバッテリーを使用する。
C	1 3	0 1	フォーマットしていない“メモリーステック デュオ”を入れた“メモリーステック デュオ”が壊れている	“メモリーステック デュオ”をフォーマットする。 新しい“メモリーステック デュオ”に交換する。
C	1 3	0 2	アクセスエラー	電源を外し、再度入れ直してから操作する。
C	3 2	6 0	フォーカスが合いにくい (フォーカスの初期化ができない)	操作スイッチの電源を入れ直す。 復帰しない場合、レンズブロックのフォーカスMRセンサ (LD-235基板CN5202 ①, ②ピン) を点検する。異常なければフォーカスマータ駆動回路 (LD-235基板IC5201) を点検する。
E	2 0	0 0	フラッシュメモリが書き換えられている	フラッシュメモリのデータを元の値に戻す。(注意1)
E	6 1	1 0	ズーム動作の異常 (ズームレンズの初期化ができない)	ズームレバーを操作したときにズーム動作をすれば、レンズブロックのズームリセットセンサ (LD-235基板CN5202 ⑳ピン) を点検する。ズーム動作をしなければズームモータ駆動回路 (LD-235基板IC5201) を点検する。
E	6 1	1 1	フォーカス, ズーム異常	自己診断コードC:32:60とE:61:10の両方を点検する。
E	6 2	0 0	手振れ補正が効きにくい (PITCH角速度センサ出力張り付き)	PITCH/YAW角速度センサ (SE-174基板SE6602) 周辺回路を点検する。
E	6 2	0 1	手振れ補正が効きにくい (YAW角速度センサ出力張り付き)	PITCH/YAW角速度センサ (SE-174基板SE6602) 周辺回路を点検する。
E	9 1	0 1	フラッシュの充電異常	フラッシュユニットの点検または交換をする。
E	9 4	0 0	フラッシュメモリの書込み/消去動作不良	フラッシュメモリ (VC-522基板IC2101) を点検する。

注意1: ADJ編, (「1-3. DESTINATION DATA WRITE」) を参照してください。

注意2: レンズブロックを交換した場合は, ADJ編を参照して必要な調整項目を実施すること。調整後は手振れ補正ONの状態にして, 手持ち動作で手振れ補正が適切に動作していることを確認する。

1-4. キャビネット(L)交換時の注意

1-4-1. キャビネット(L)注文時の注意

機種ごとの表示部はレーザー印字方式を採用しております。
この為、交換用のキャビネット (L) は機種、仕向けにより異なります。類似の表示もありますので、該当するものを選んで注文してください。

注意：キャビネット (L) 交換後はシリアルナンバーがサービス専用のシリアルナンバーに変更されます。お客様への案内と修理データのシリアルナンバー変更を行ってください。

HDR-TG1 (J仕向)

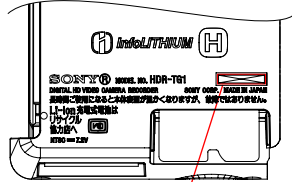

シリアルナンバー

部品コード 部品名

A-1542-400-A サービス用キャビ` (L (TG1-J1))

HDR-TG1 (US仕向)

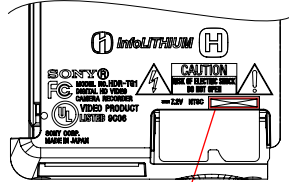

シリアルナンバー

部品コード 部品名

A-1542-402-A サービス用キャビ` (L (TG1-U2))

HDR-TG1 (CND仕向)

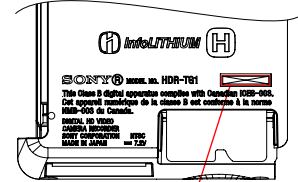

シリアルナンバー

部品コード 部品名

A-1542-403-A サービス用キャビ` (L (TG1-CA2))

HDR-TG1 (KR仕向)

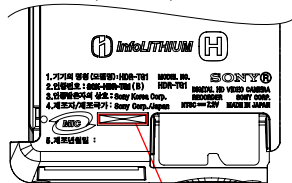

シリアルナンバー

部品コード 部品名

A-1542-404-A サービス用キャビ` (L (TG1-KR2))

HDR-TG1 (E, JE仕向)

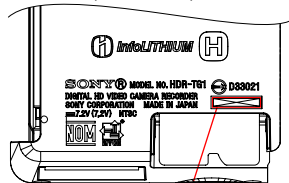

シリアルナンバー

部品コード 部品名

A-1542-405-A サービス用キャビ` (L (TG1-E23))

HDR-TG1E (NE仕向)

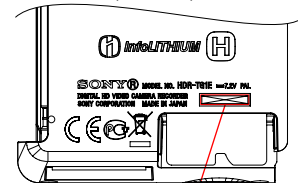

シリアルナンバー

部品コード 部品名

A-1542-406-A サービス用キャビ` (L (TG1-CEL))

HDR-TG1E (E, HK, AUS, JE仕向)

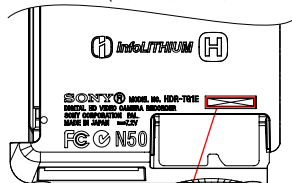

シリアルナンバー

部品コード 部品名

A-1542-407-A サービス用キャビ` (L (E34))

HDR-TG1E (CH仕向)

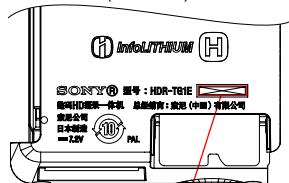

シリアルナンバー

部品コード 部品名

A-1542-408-A サービス用キャビ` (L (CN2))

HDR-TG3E (NE仕向)

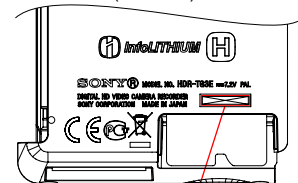

シリアルナンバー

部品コード 部品名

A-1542-409-A サービス用キャビ` (L (TG3-CEL))

HDR-TG3E (AEP, UK仕向)

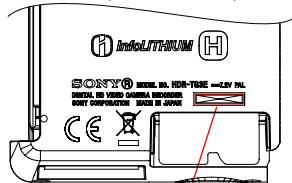

シリアルナンバー

部品コード 部品名

A-1542-410-A サービス用キャビ` (L (TG3-CEN))

1-4-2. 日本向けモデルのキャビネット(L)交換時の注意

交換前のキャビネット (L) に印字されている“製造年 (下図の○部の表示)”と同じ表示のラベルを新しいキャビネット (L) に貼付けてください。

例：下図では，“08年製”のラベルを貼る

* ラベルは，サービス用キャビネット (L) 部組に「投げ込み (ラベル貼り方)」を含めて同梱されています。

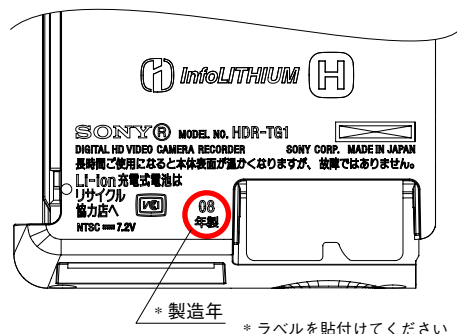

1-4-3. US向けモデルのキャビネット(L)交換時の注意

交換前のキャビネット (L) に印字されている“製造年月 (下図の○部の表示)”と同じ表示のラベルを新しいキャビネット (L) に貼付けてください。

例：下図では，“8A”と“SKD”のラベルを貼る

* ラベルは，サービス用キャビネット (L) に「投げ込み (ラベル貼り方)」を含めて同梱されています。

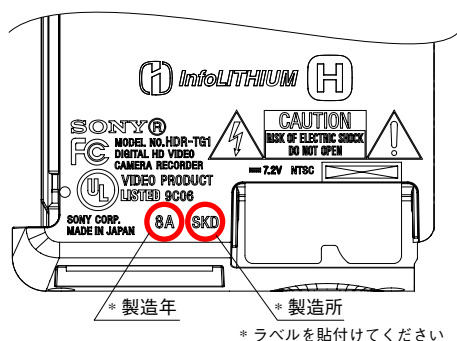

1-4-4. 韓国向けモデルのキャビネット(L)交換時の注意

交換前のキャビネット (L) に印字されている“製造年月 (下図の○部の表示)”と同じ表示のラベルを新しいキャビネット (L) に貼付けてください。

例：下図では，“2008.2”のラベルを貼る

* ラベルは，サービス用キャビネット (L) に「投げ込み (ラベル貼り方)」を含めて同梱されています。

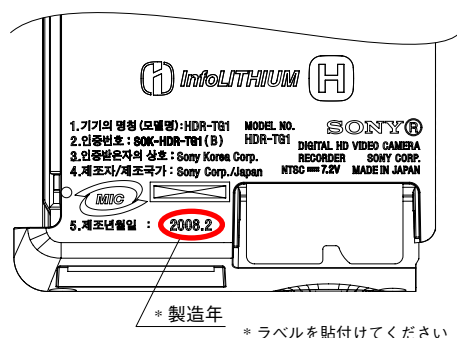

2. DISASSEMBLY

NOTE FOR REPAIR

- Make sure that the flat cable and flexible board are not cracked or bent at the terminal. Do not insert the cable insufficiently nor crookedly.
- When remove a connector, don't pull at wire of connector. It is possible that a wire is snapped.
- When installing a connector, don't press down at wire of connector. It is possible that a wire is snapped.

Cut and remove the part of gilt which comes off at the point.
(Be careful or some pieces of gilt may be left inside)

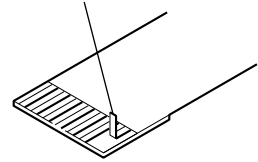

DISCHARGING OF FP-914 FLEXIBLE BOARD'S CHARGING CAPACITOR (C001)

The charging capacitor (C001) of FP-914 flexible board is charged up to the maximum 330 V potential.

There is a danger of electric shock by this high voltage when the capacitor is handled by hand. The electric shock is caused by the charged voltage which is kept without discharging when the main power of the unit is simply turned off. Therefore, the remaining voltage must be discharged as described below.

Preparing the Short Jig

To preparing the short jig, a small clip is attached to each end of a resistor of 1 k Ω / 1 W (1-215-869-11).

Wrap insulating tape fully around the leads of the resistor to prevent electrical shock.

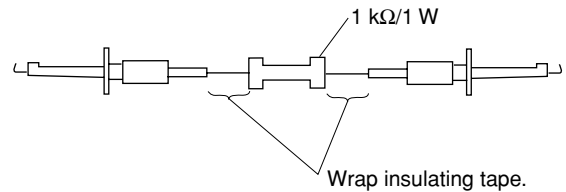

Note: High-voltage cautions

Discharging the Capacitor

Short-circuit between two points with the short jig about 10 seconds.

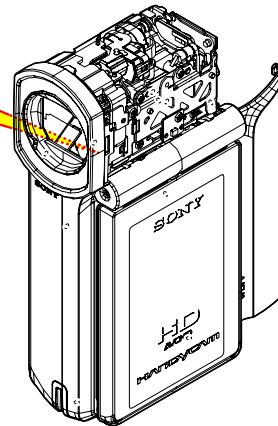
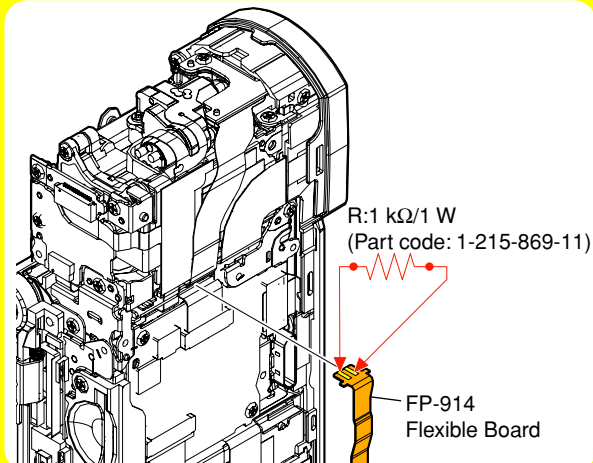

2-1. IDENTIFYING PARTS

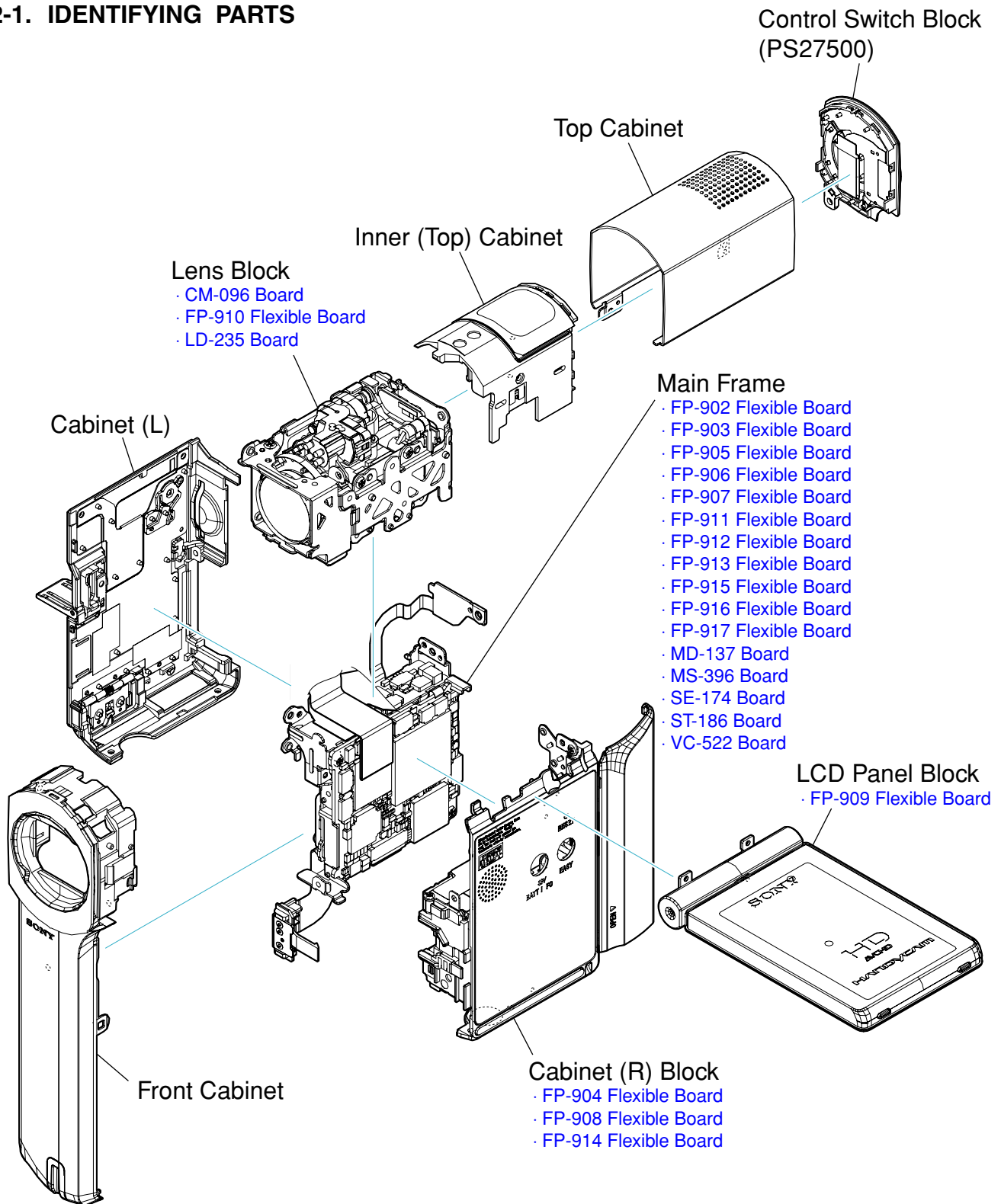

- DISASSEMBLY FLOW -

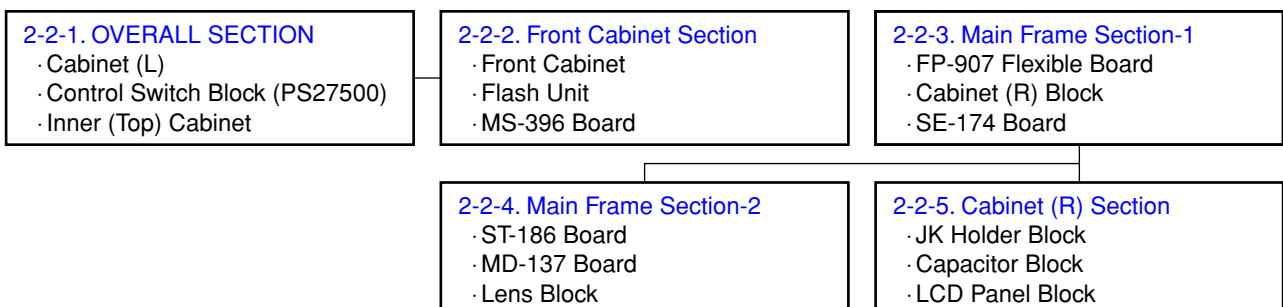

2-2. DISASSEMBLY

EXPLODED VIEW

HARDWARE LIST

2-2-1. OVERALL SECTION

Follow the disassembly in the numerical order given.

- ① Cabinet (L) (①-1 to ①-5)
- ② Control Switch Block (PS27500) (②-1 to ②-3)
- ③ Inner (Top) Cabinet (③-1 to ③-9)

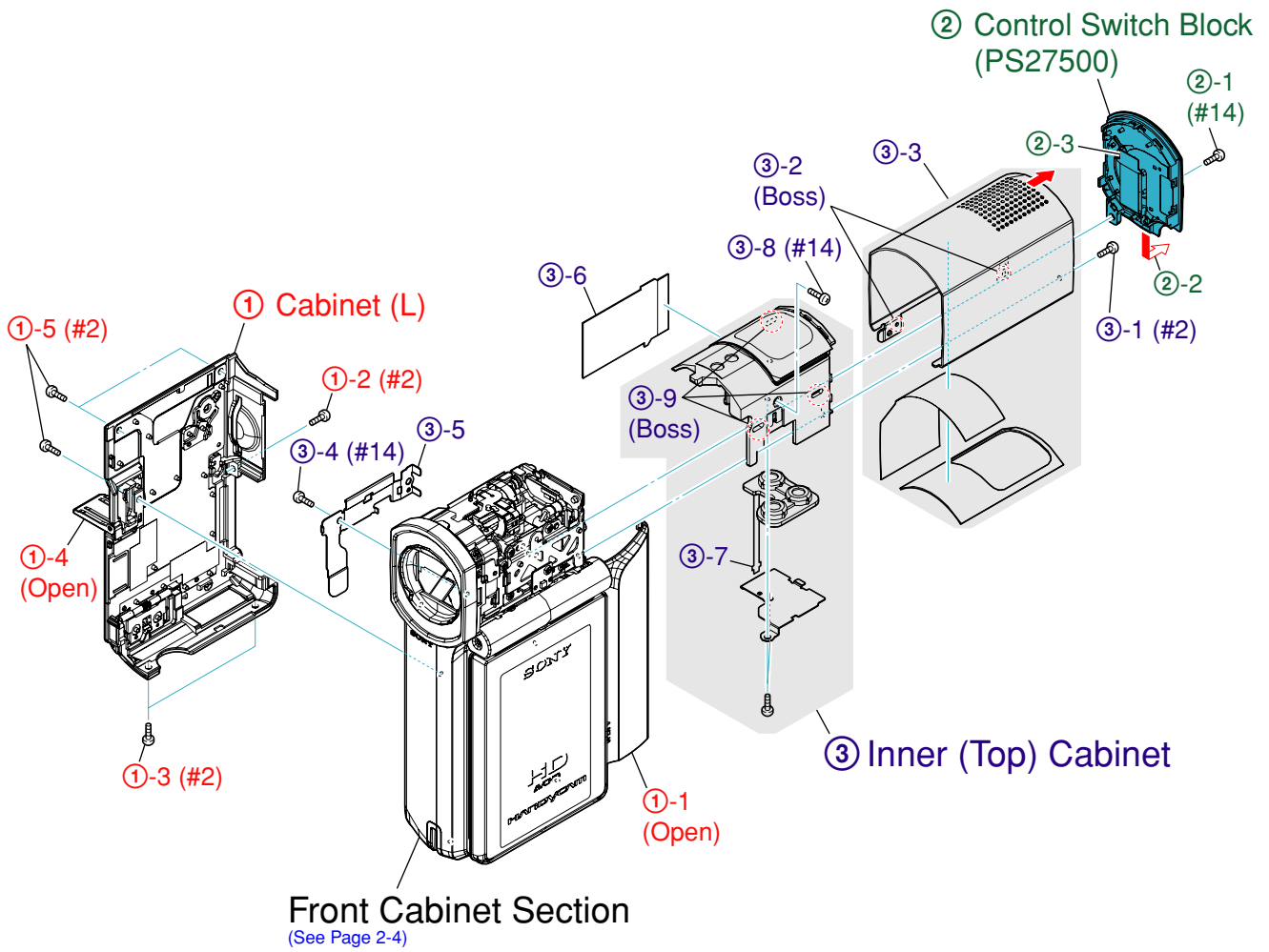

2-2-2. FRONT CABINET SECTION

Follow the disassembly in the numerical order given.

- ① Front Cabinet (①-1 to ①-5)
- ② Flash Unit (②-1 to ②-3)
- ③ MS-396 board (③-1 to ③-6)

EXPLODED VIEW

HARDWARE LIST

Note: High-voltage cautions

Discharging the Capacitor

Short-circuit between two points with the short jig about 10 seconds.

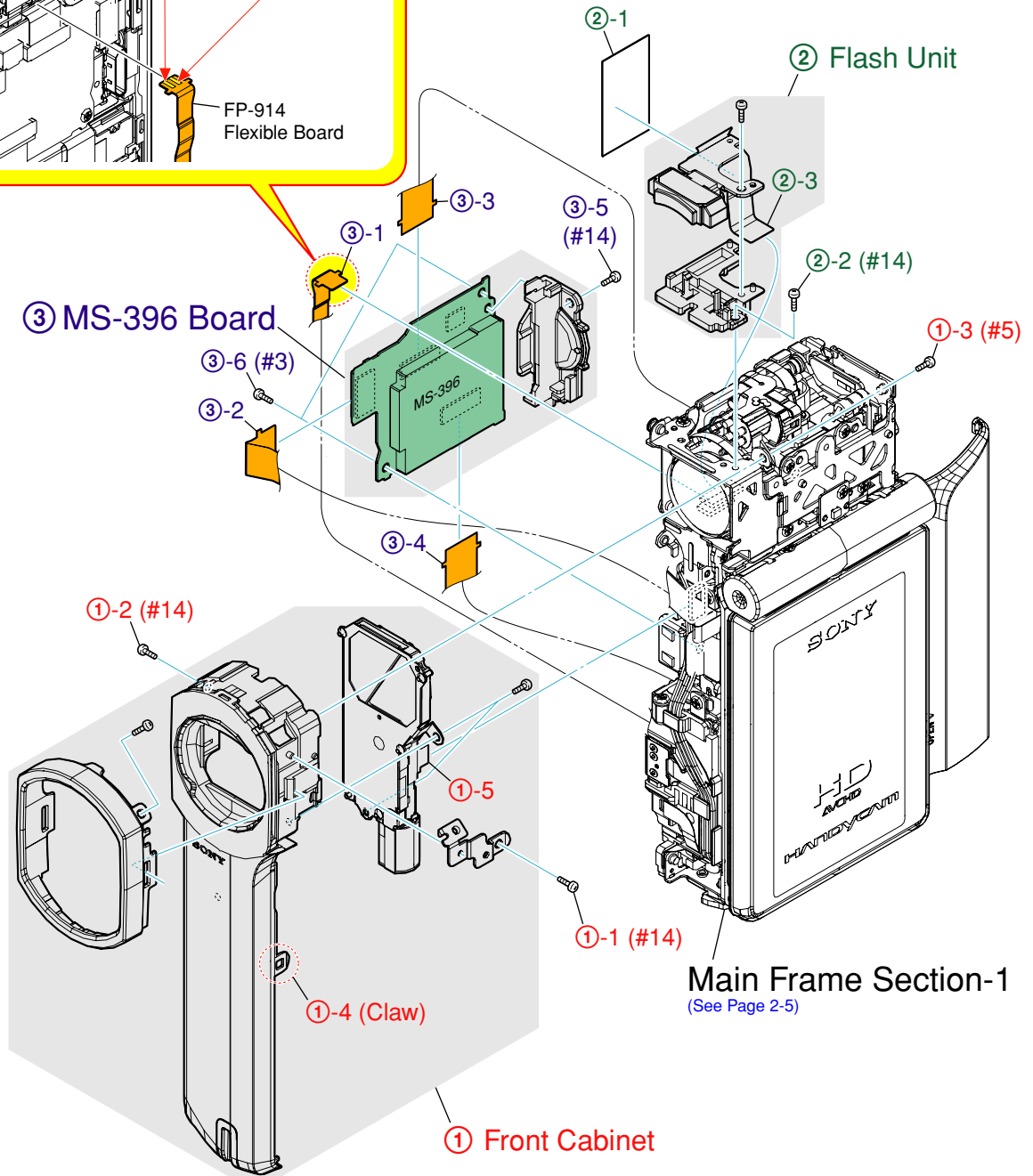
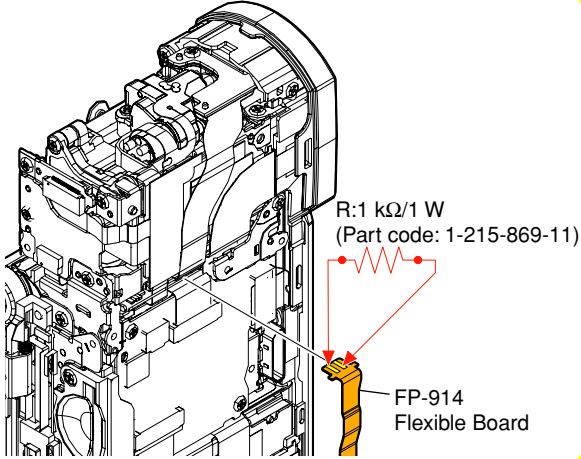

2-2-3. MAIN FRAME SECTION-1

Follow the disassembly in the numerical order given.

- ① FP-907 Flexible Board (①-1 to ①-4)
- ② Cabinet (R) Block (②-1 to ②-6)
- ③ SE-174 Board (③-1 to ③-9)

EXPLODED VIEW

HARDWARE LIST

Main Frame Section-2

(See Page 2-6)

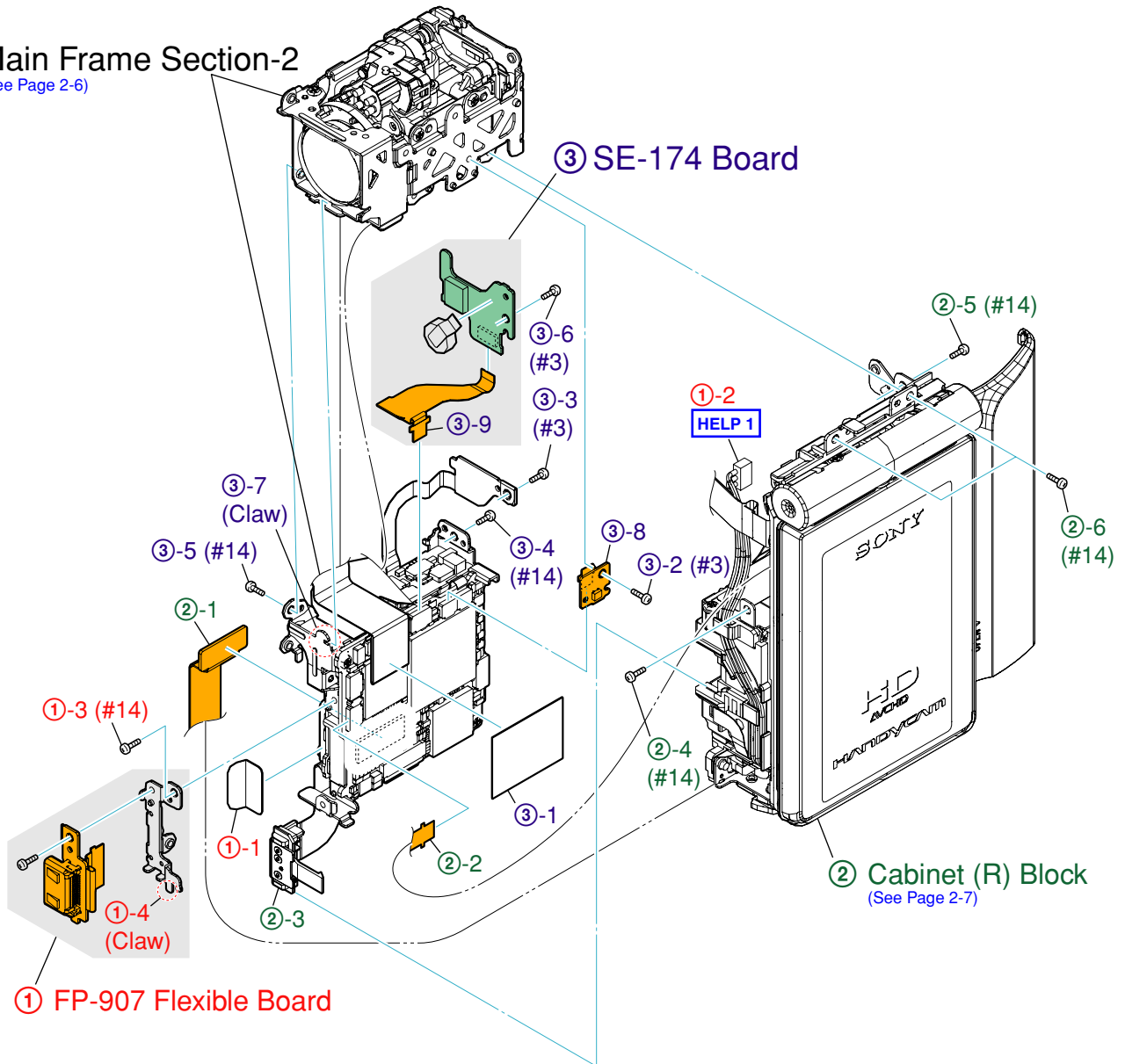

2-2-4. MAIN FRAME SECTION-2

Follow the disassembly in the numerical order given.

- ① ST-186 Board (①-1 to ①-4)
- ② MD-137 Board (②-1 to ②-6)
- ③ Lens Block (③-1 to ③-3)

EXPLODED VIEW

HARDWARE LIST

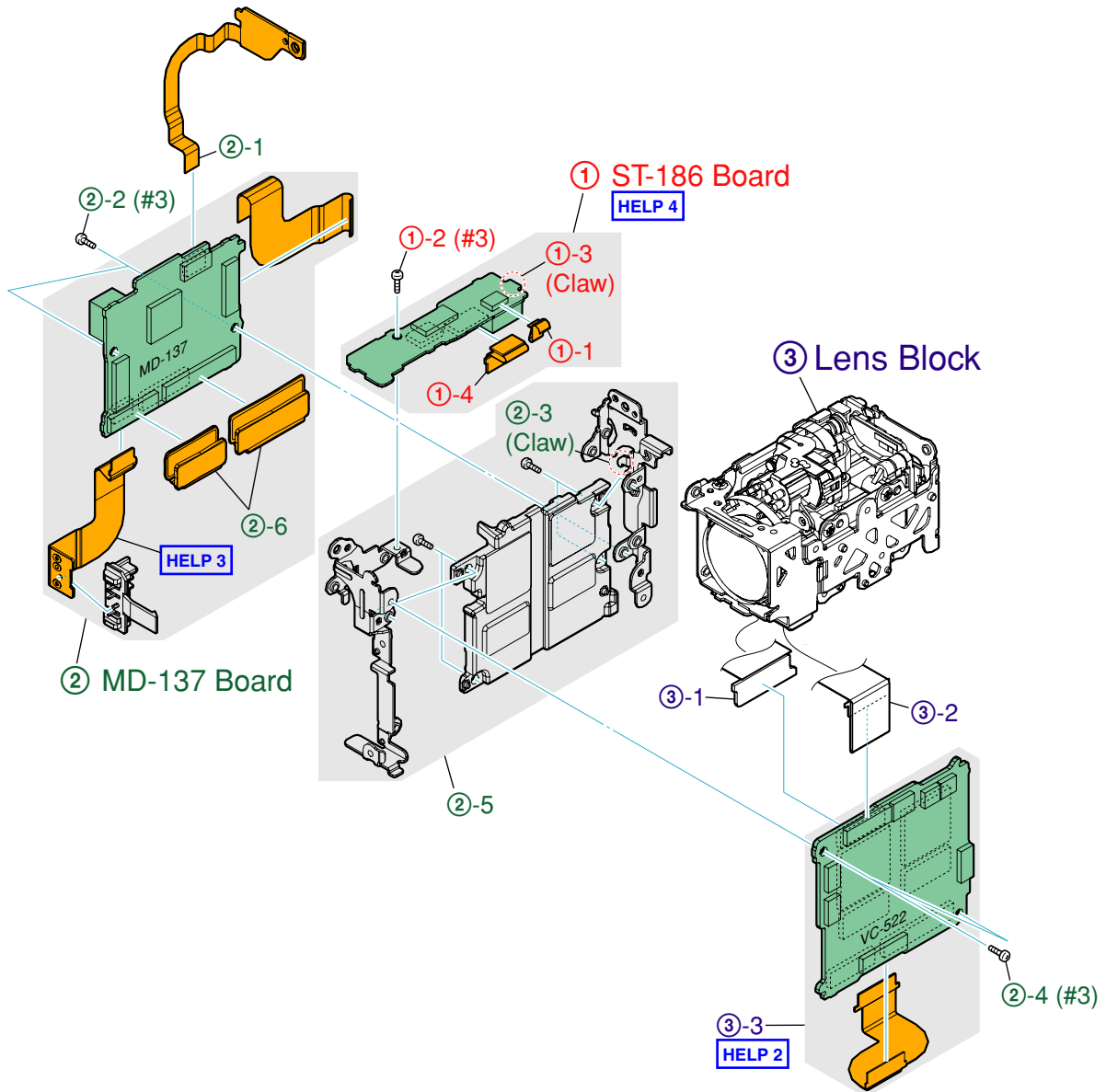

2-2-5. CABINET (R) SECTION

Follow the disassembly in the numerical order given.

- ① JK Holder Block (①-1 to ①-5)
- ② Capacitor Block (②-1 to ②-2)
- ③ LCD Panel Block (③-1 to ③-13)

EXPLODED VIEW

HARDWARE LIST

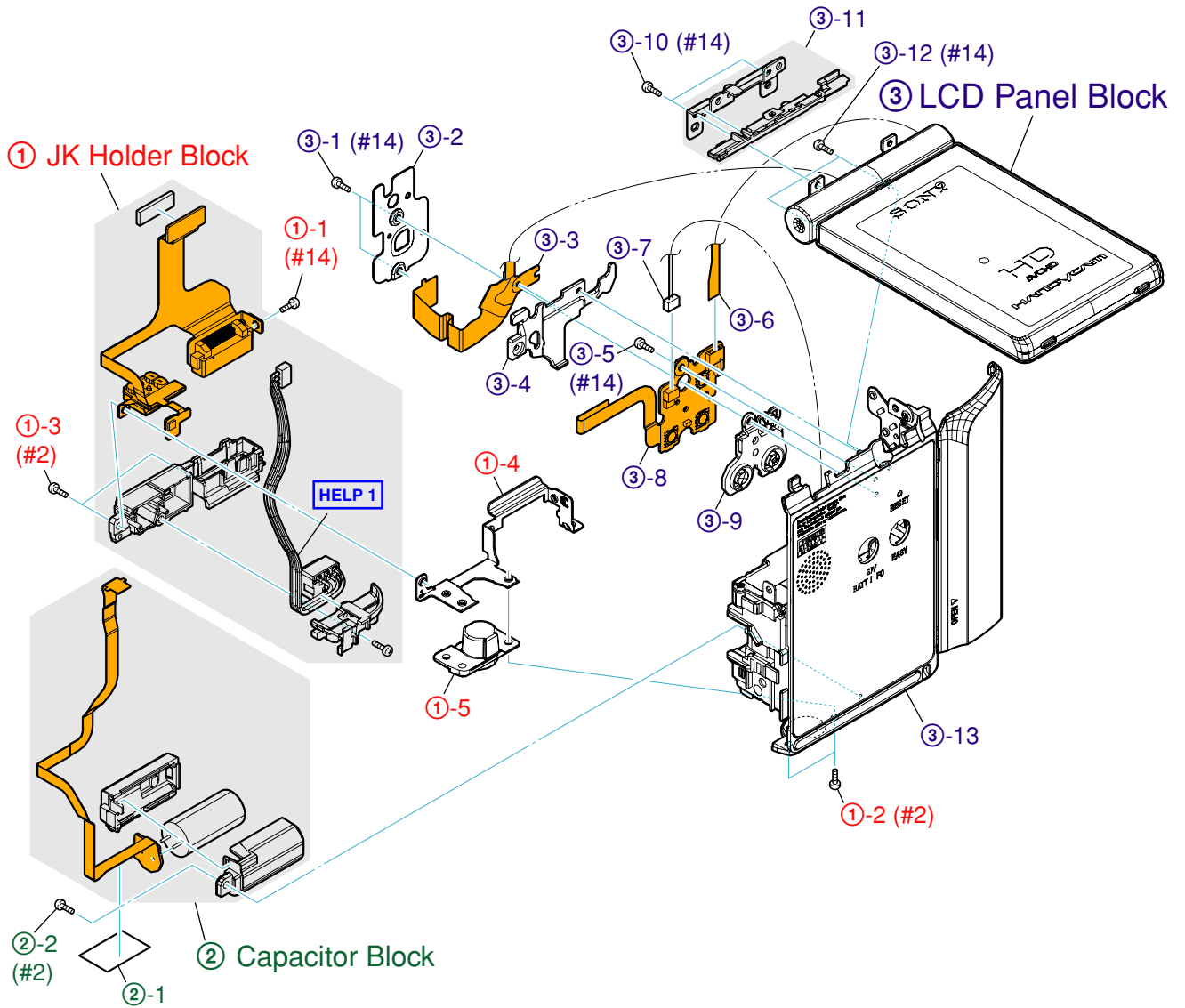

HELP

Sheet attachment positions and procedures of processing the flexible boards/harnesses are shown.

HELP 1: DC Jack Harness

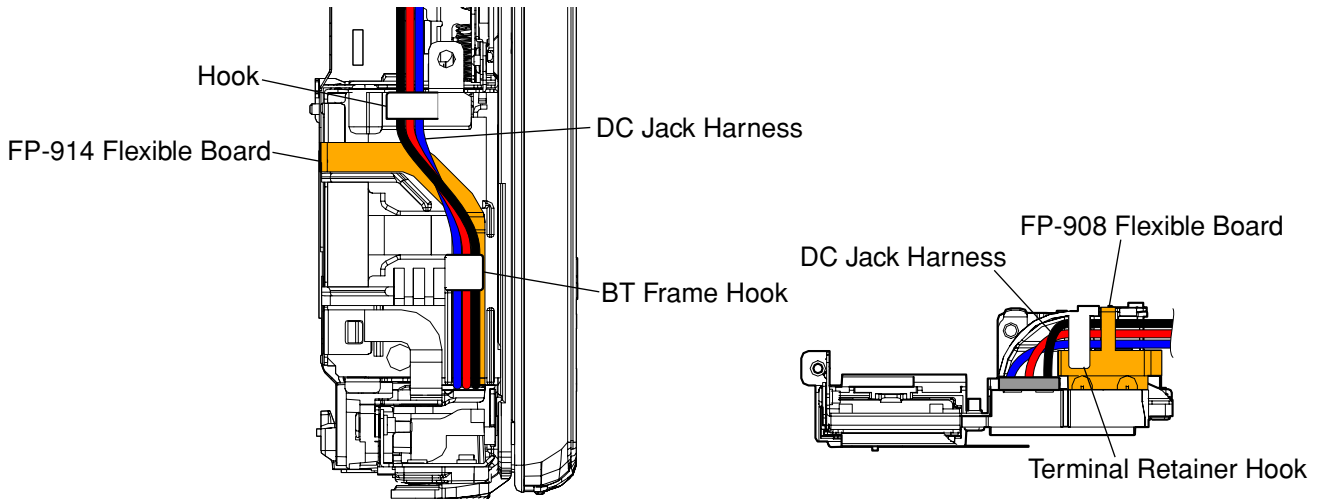

HELP 2: Radiation Sheet (A)/AG Copy Sheet

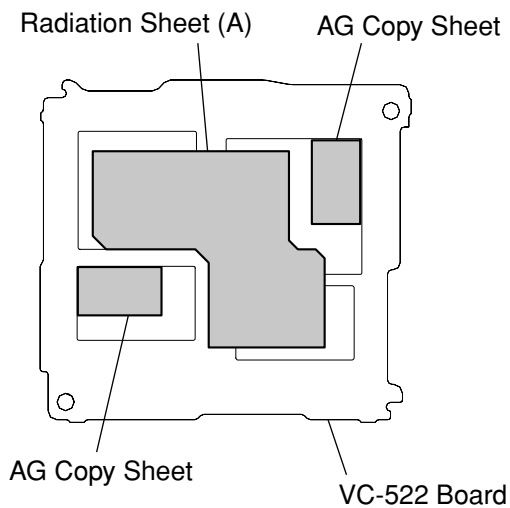

HELP 3: FP-917 Flexible Board

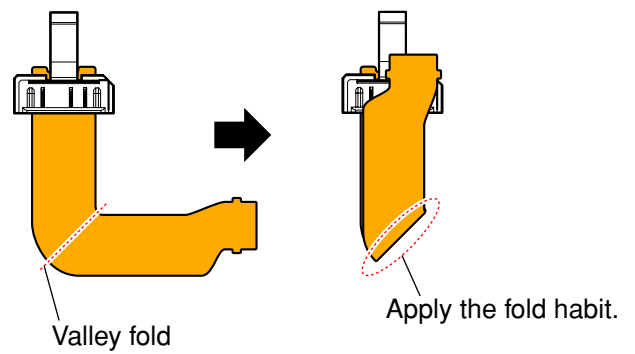

HELP 4: The Method of Attachment of ST-186 Board

- ① Apply folds to the FP-915 flexible board as shown in the figure below.
- ② Install the FP-915 flexible board to CN7503 of ST-186 board.
- ③ Install the FP-912 flexible board to CN7501 of ST-186 board.
- ④ Prepare the stand of about 20 mm in height, and set it as shown in the figure below.
- ⑤ Install the FP-915 flexible board to CN1112 of MD-137 board.
- ⑥ Insert the claw of ST-186 board in the main frame.
- ⑦ Tighten the screw.

CN7503 of ST-186 Board (Side A)

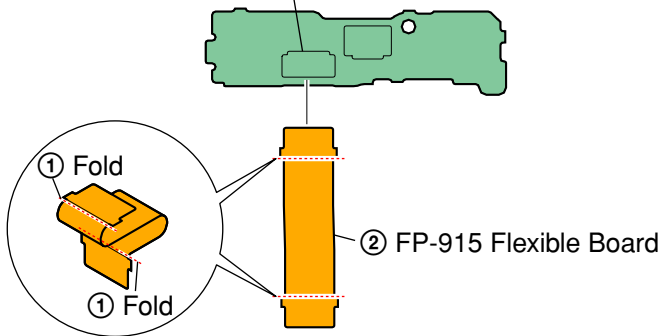

- ③ Install the FP-912 flexible board to CN7501 of ST-186 board.

CN7501 of ST-186 Board (Side B)

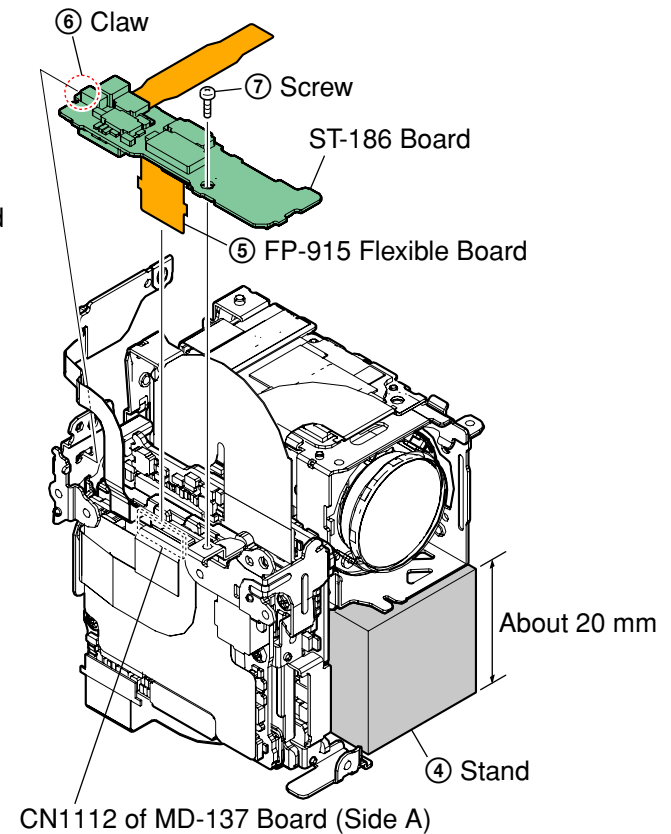
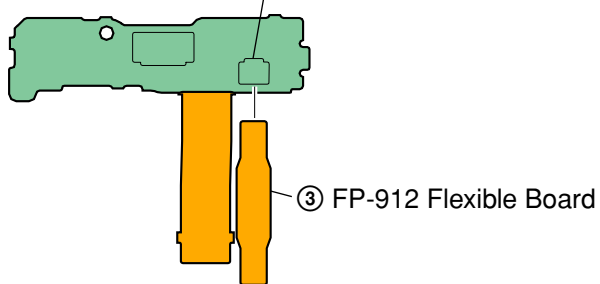

- ⑧ Install the FP-912 flexible board to CN1026 of VC-522 board.

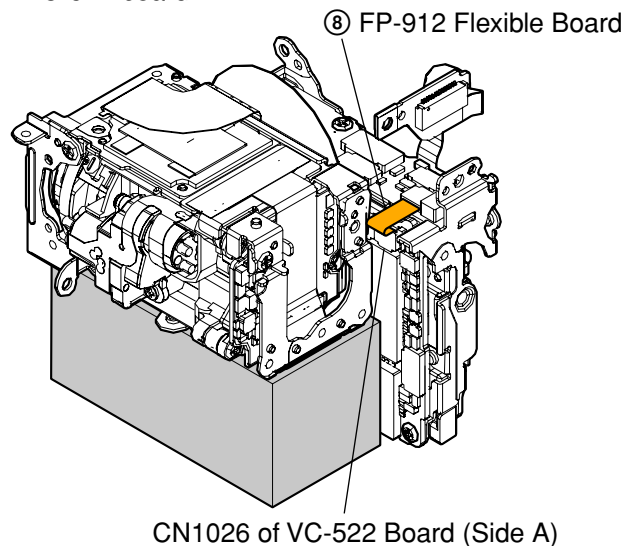

HELP 5: The Method of Attachment of FP-909 Flexible Board

- ① Apply folds to the FP-909 flexible board as shown in the figure below.
- ② Stick adhesive tapes.
- ③ Match the position of the hole, and stick adhesive tapes.
- ④ Paste the JN copy sheet.
- ⑤ Install the hinge clamp to the FP-909 flexible board.
- ⑥ Install the hinge assy to the hinge clamp.

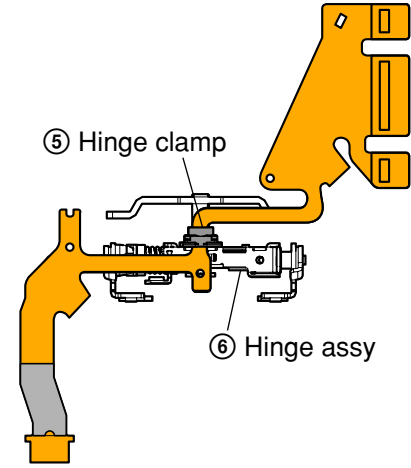
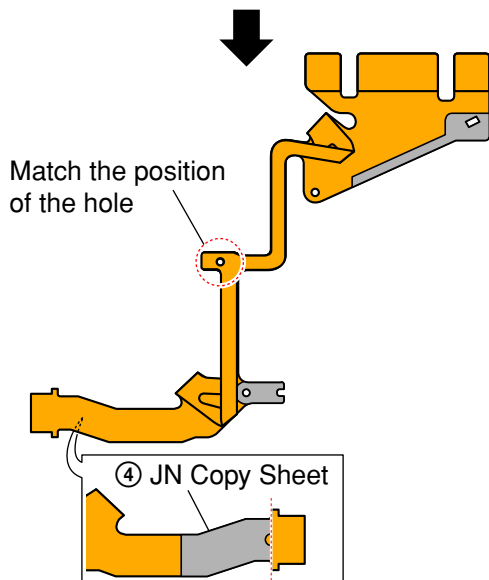
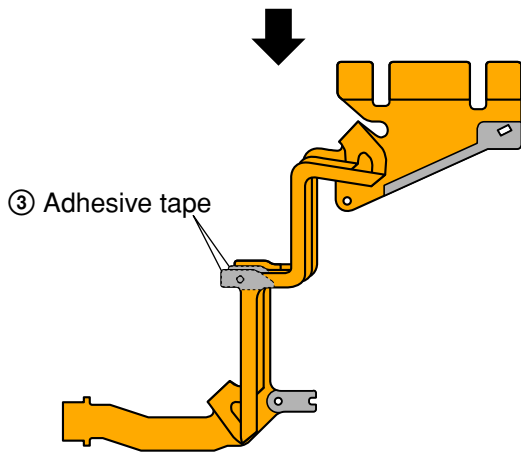
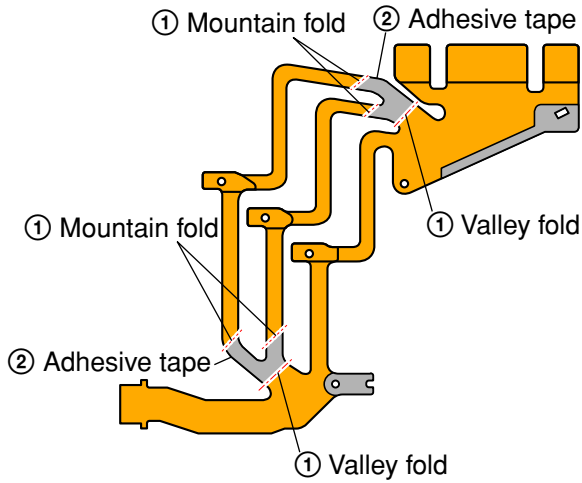

- ⑦ Rotate the hinge assy.
- ⑧ Match the position of the boss, and stick adhesive tapes.
- ⑨ Rotate the hinge clamp, and fix the FP-909 flexible board.

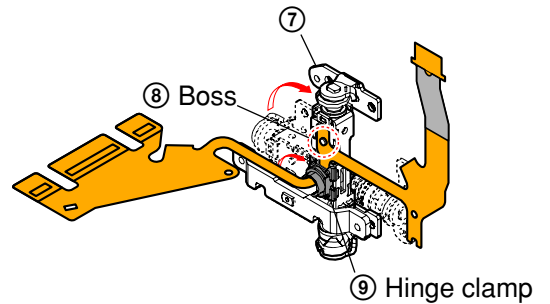

- ⑩ Install the hinge cover (rear).
- Note:** Confirm the FP-909 flexible board is fixed.
- ⑪ Tighten the screw.

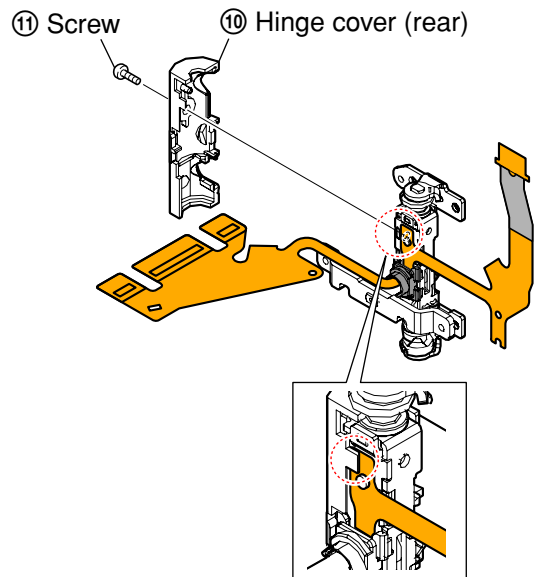

3. BLOCK DIAGRAMS

Link

OVERALL BLOCK DIAGRAM (1/7)	OVERALL BLOCK DIAGRAM (6/7)
OVERALL BLOCK DIAGRAM (2/7)	OVERALL BLOCK DIAGRAM (7/7)
OVERALL BLOCK DIAGRAM (3/7)	POWER BLOCK DIAGRAM (1/3)
OVERALL BLOCK DIAGRAM (4/7)	POWER BLOCK DIAGRAM (2/3)
OVERALL BLOCK DIAGRAM (5/7)	POWER BLOCK DIAGRAM (3/3)

3. BLOCK DIAGRAMS

3-1. OVERALL BLOCK DIAGRAM (1/7) () : Number in parenthesis () indicates the division number of schematic diagram where the component is located.

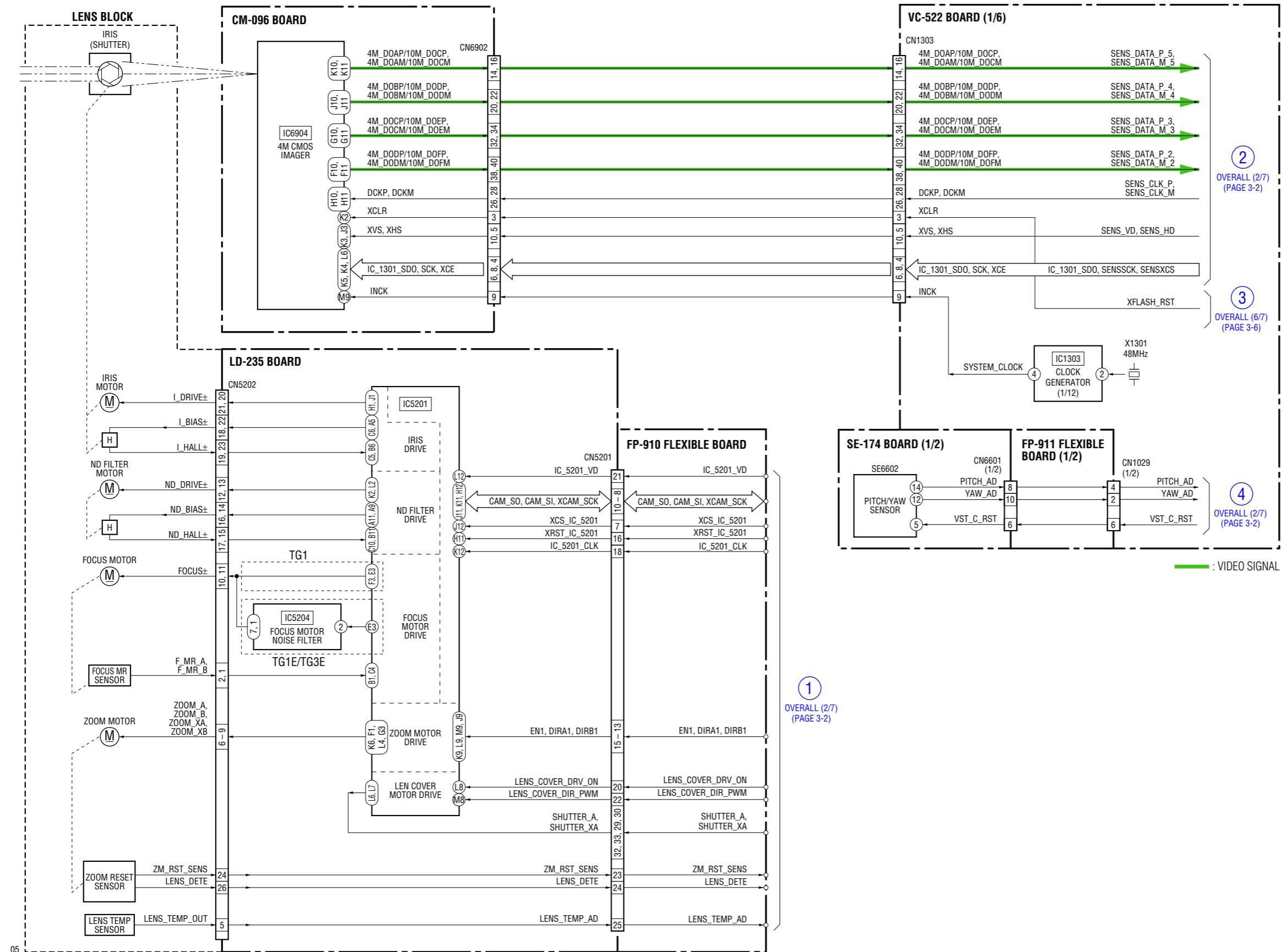

05

3-2. OVERALL BLOCK DIAGRAM (2/7) () : Number in parenthesis () indicates the division of schematic diagram where the component is located.

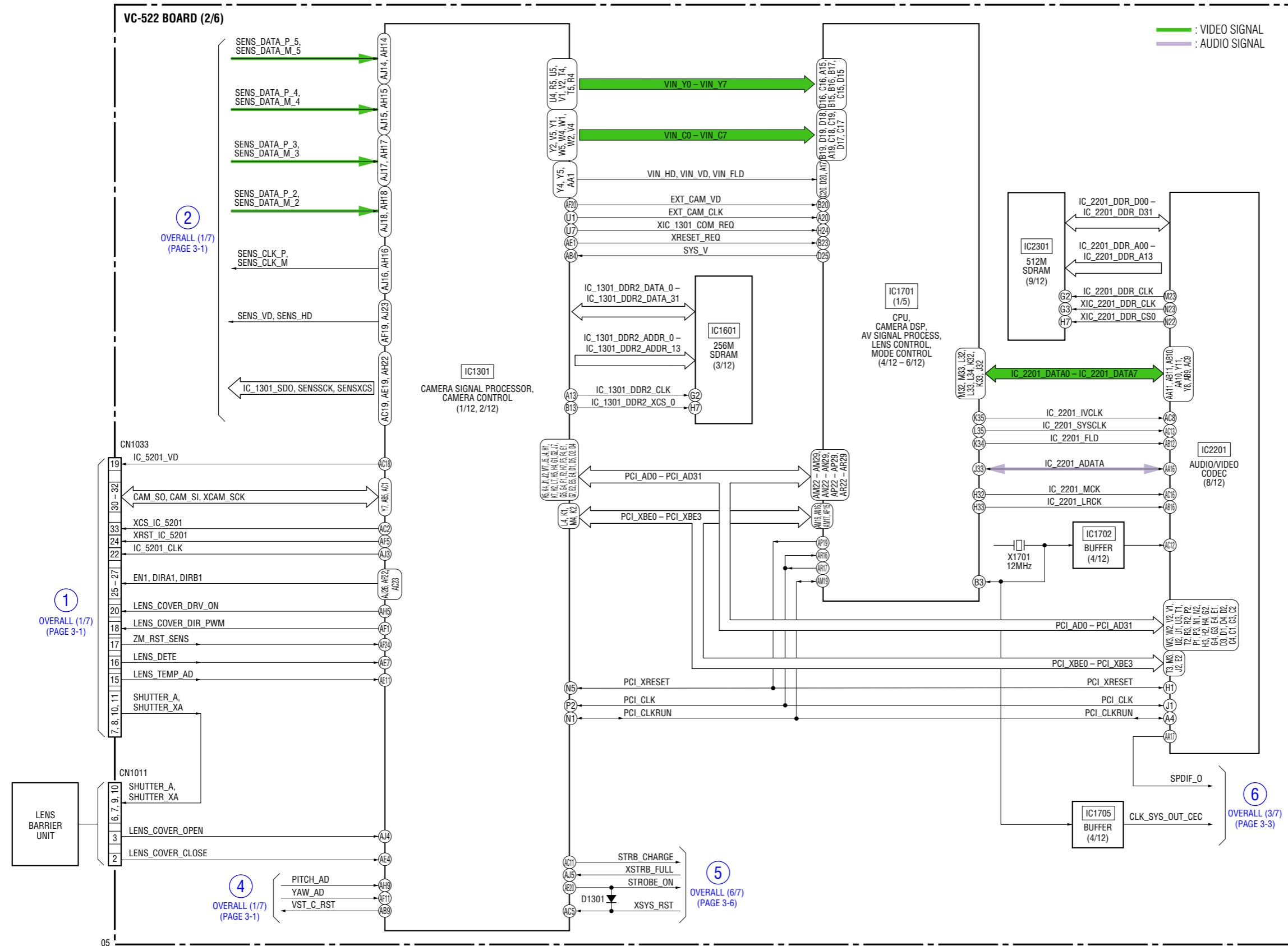

3-3. OVERALL BLOCK DIAGRAM (3/7) () : Number in parenthesis () indicates the division number of schematic diagram where the component is located.

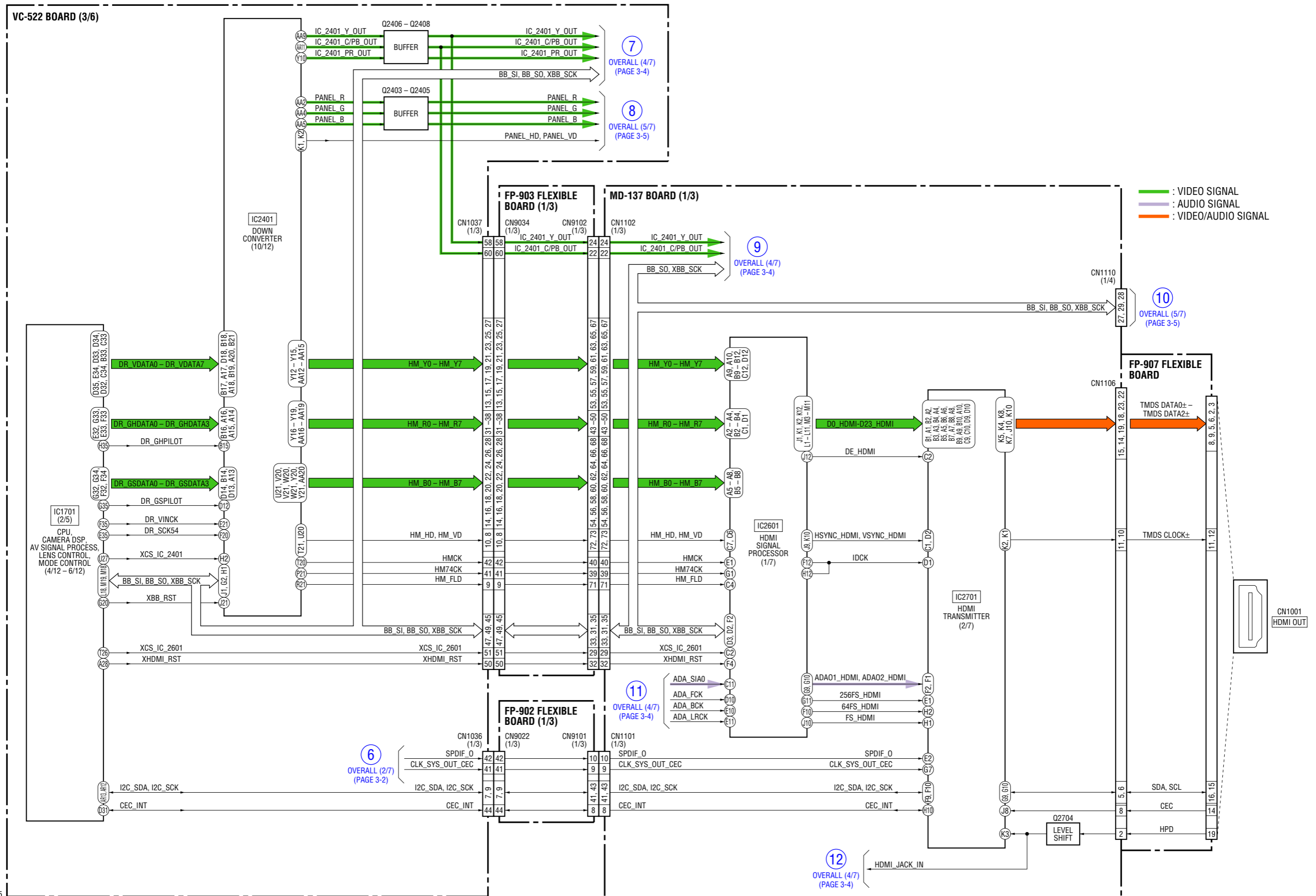

3-4. OVERALL BLOCK DIAGRAM (4/7) () : Number in parenthesis () indicates the division number of schematic diagram where the component is located.

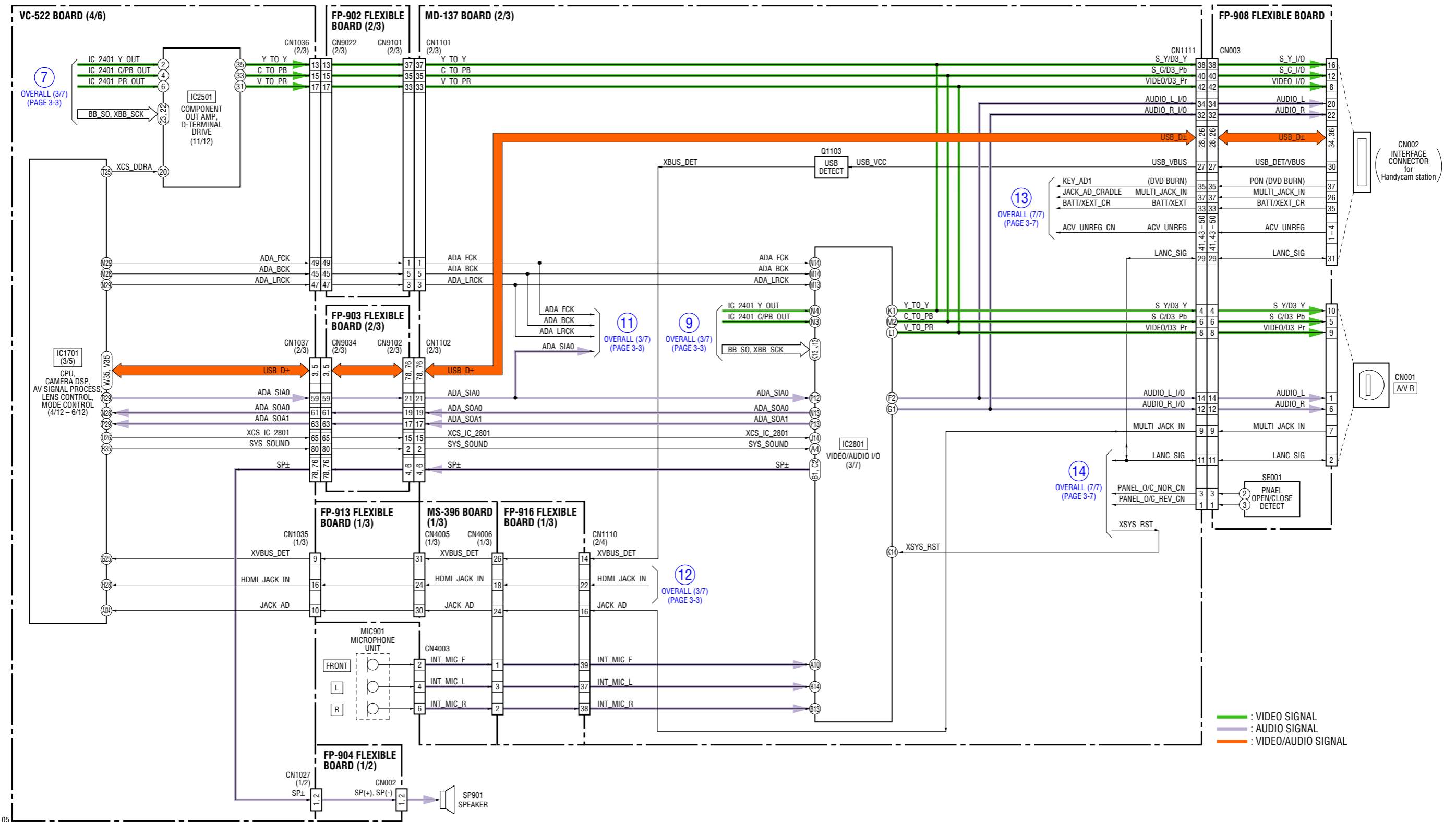

3-5. OVERALL BLOCK DIAGRAM (5/7) () : Number in parenthesis () indicates the division number of schematic diagram where the component is located.

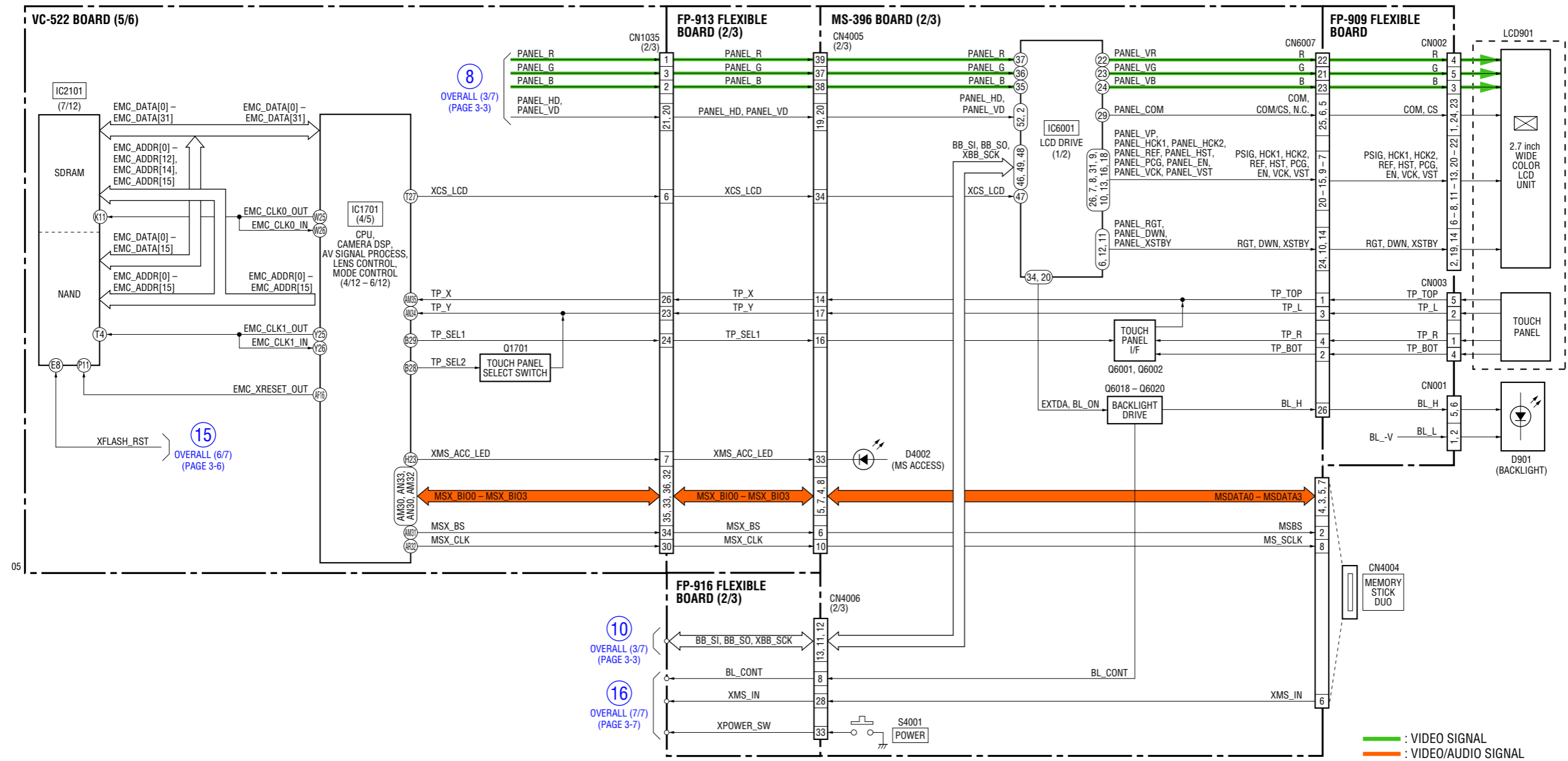

3-6. OVERALL BLOCK DIAGRAM (6/7) () : Number in parenthesis () indicates the division number of schematic diagram where the component is located.

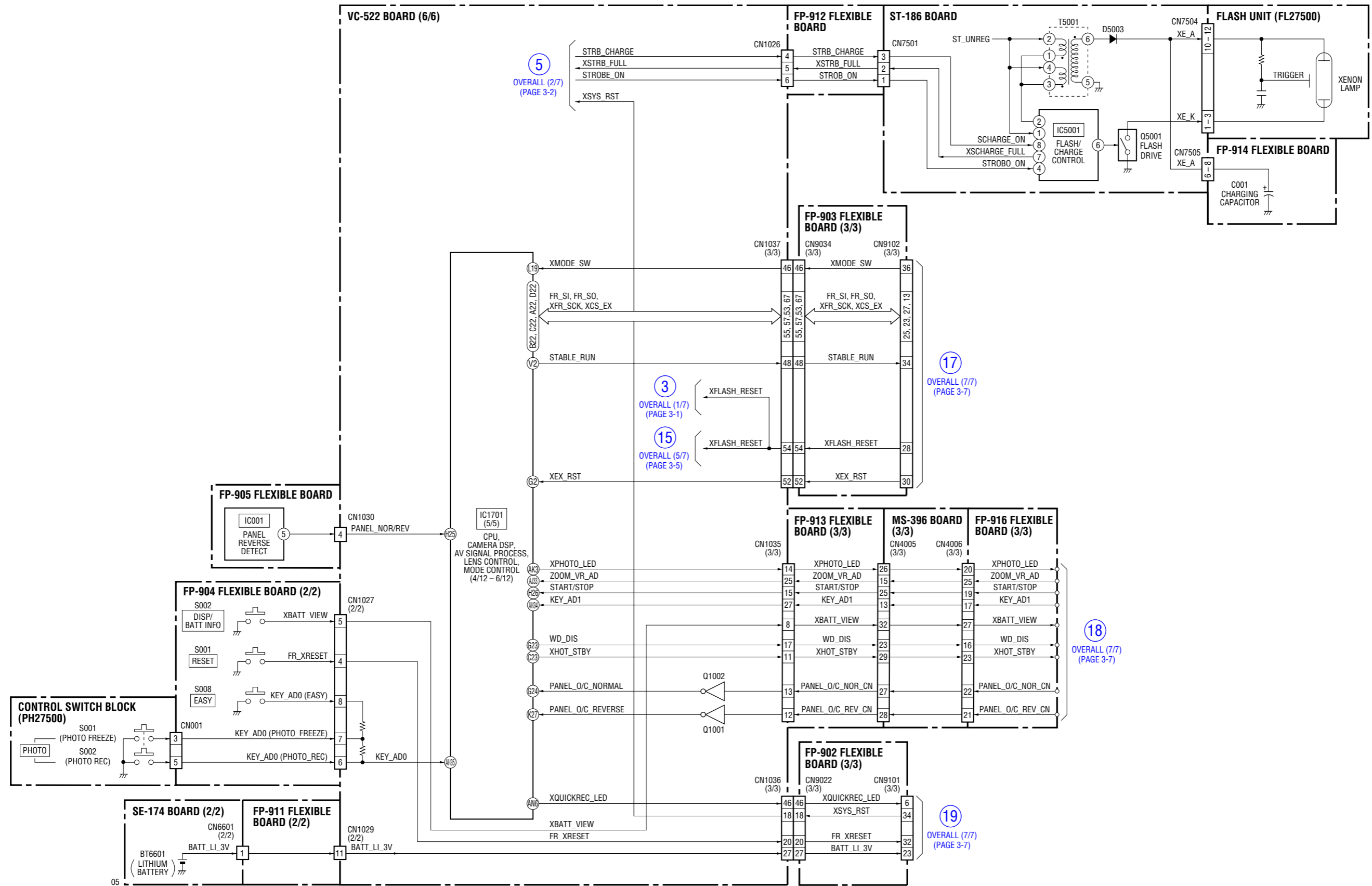

3-7. OVERALL BLOCK DIAGRAM (7/7) () : Number in parenthesis () indicates the division number of schematic diagram where the component is located.

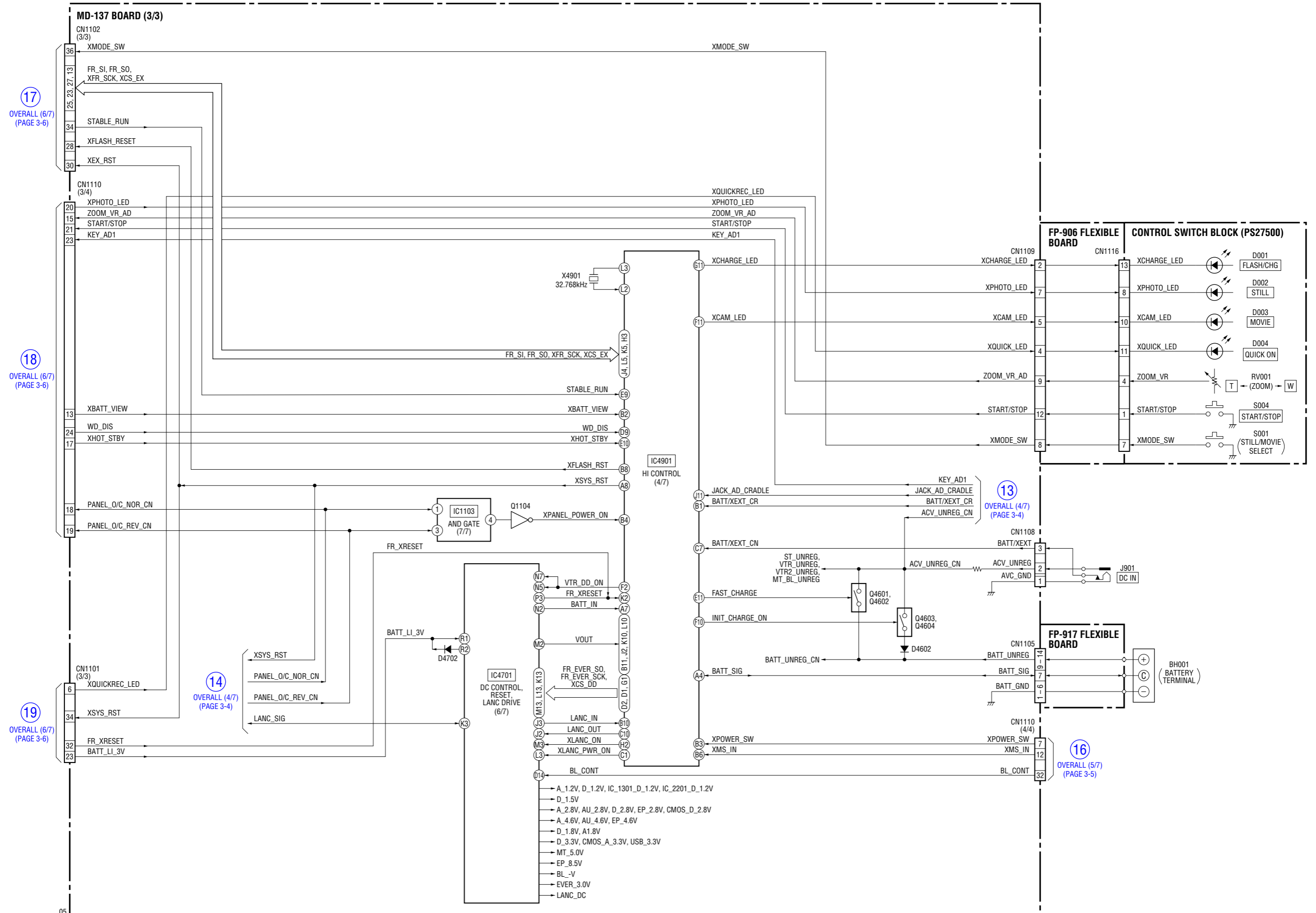

3-8. POWER BLOCK DIAGRAM (1/3) () : Number in parenthesis () indicates the division number of schematic diagram where the component is located.

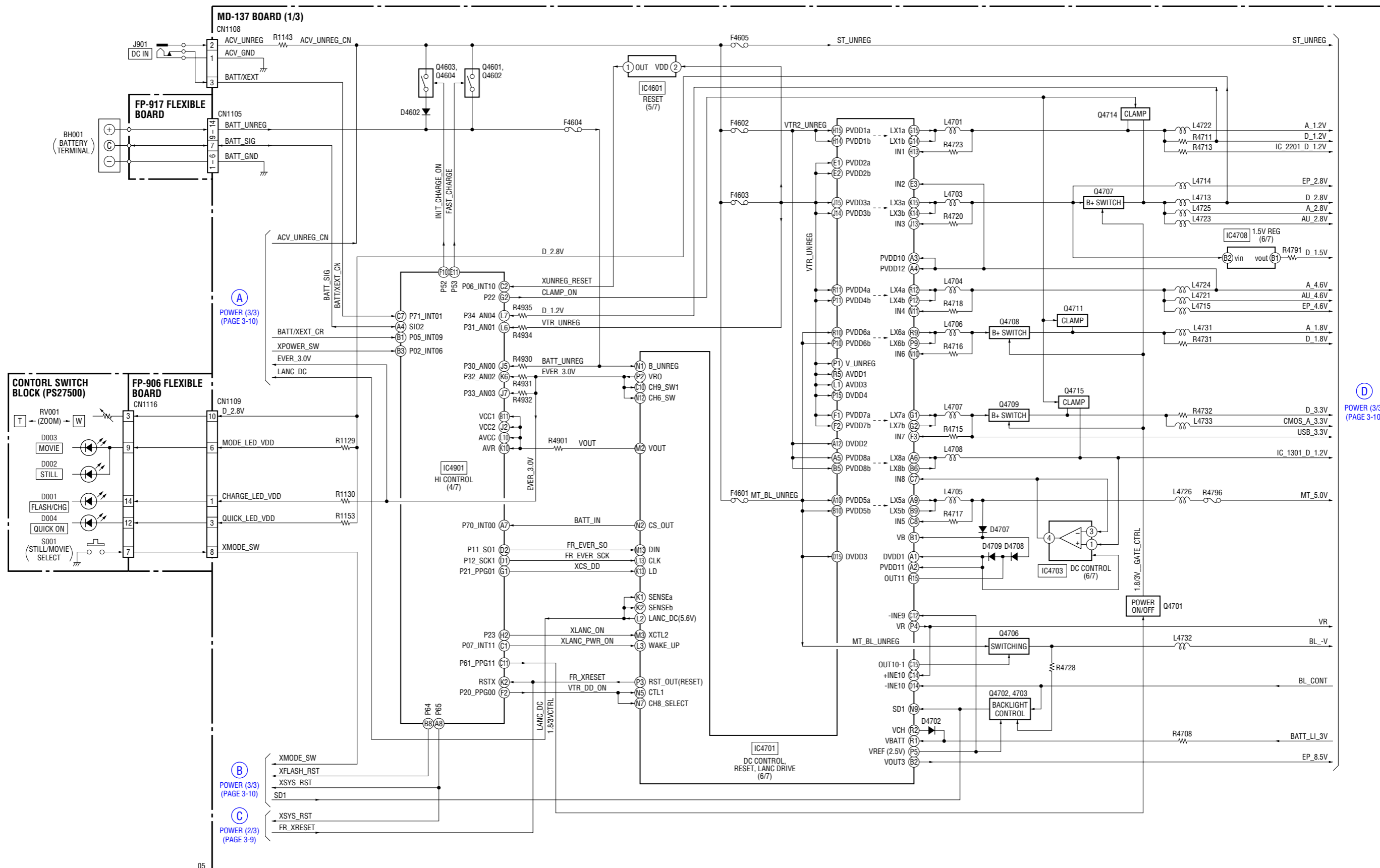

05

3-9. POWER BLOCK DIAGRAM (2/3) () : Number in parenthesis () indicates the division number of schematic diagram where the component is located.

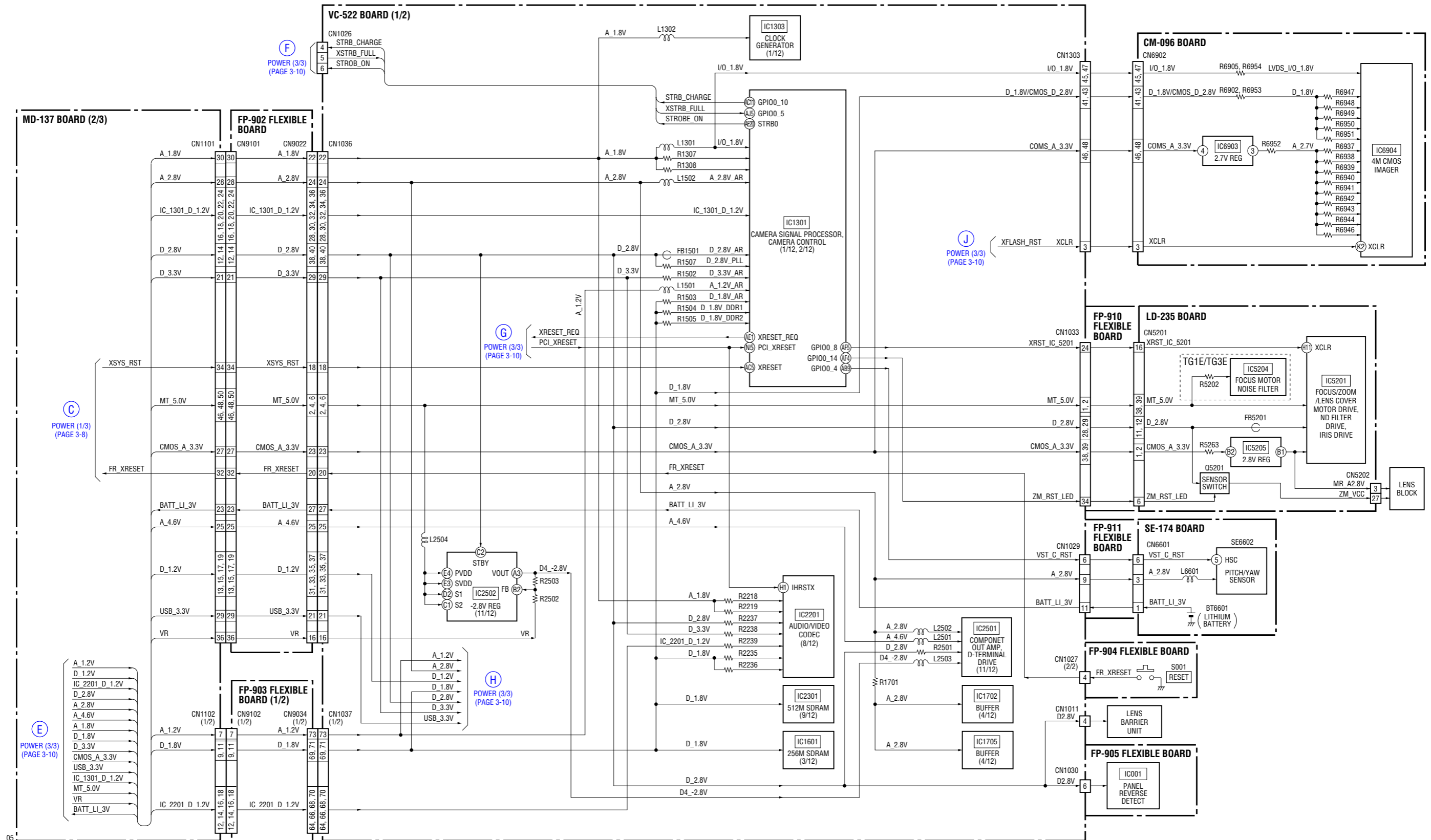

3-10. POWER BLOCK DIAGRAM (3/3) () : Number in parenthesis () indicates the division number of schematic diagram where the component is located.

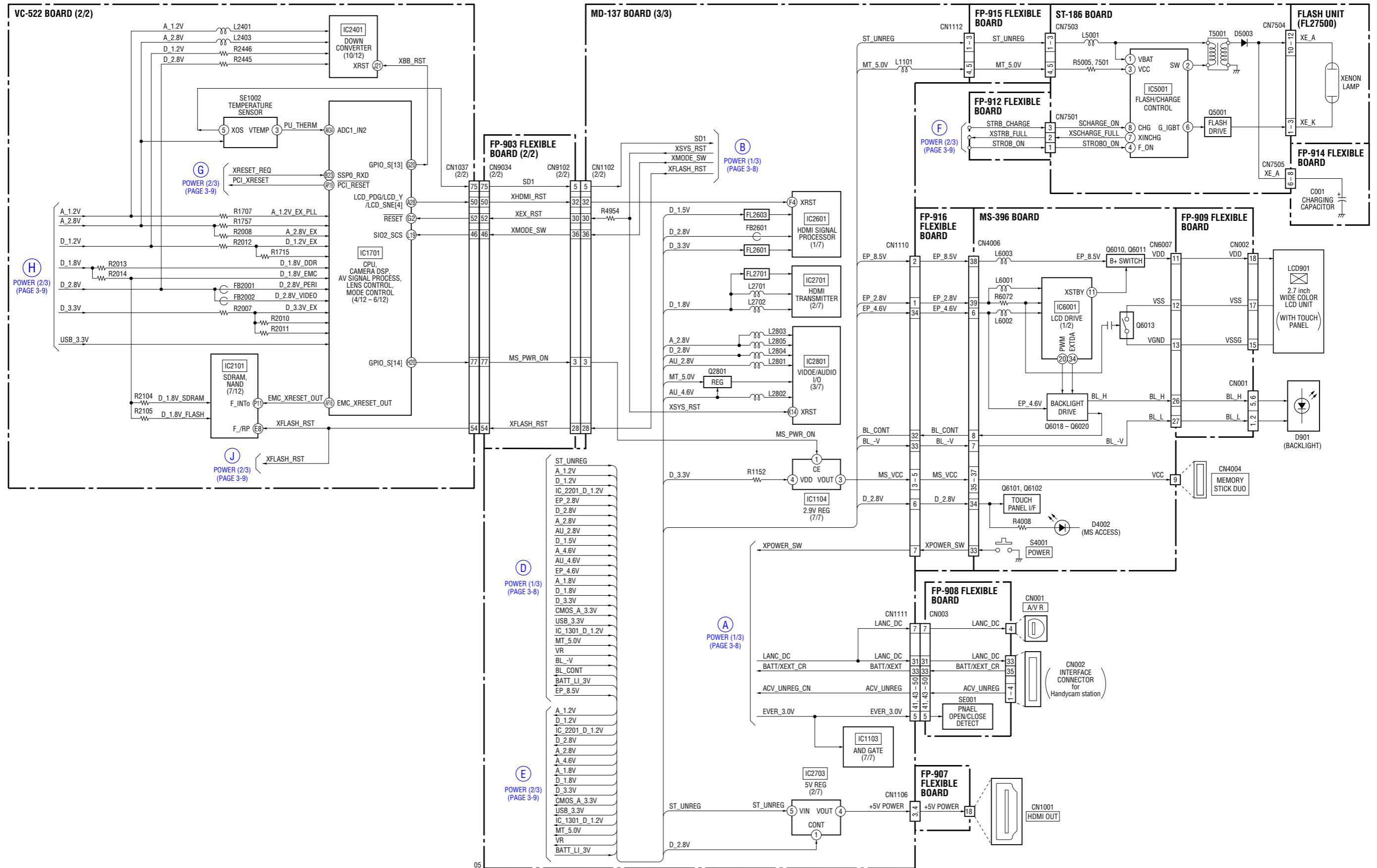

4. PRINTED WIRING BOARDS AND SCHEMATIC DIAGRAMS

4-1. FRAME SCHEMATIC DIAGRAM

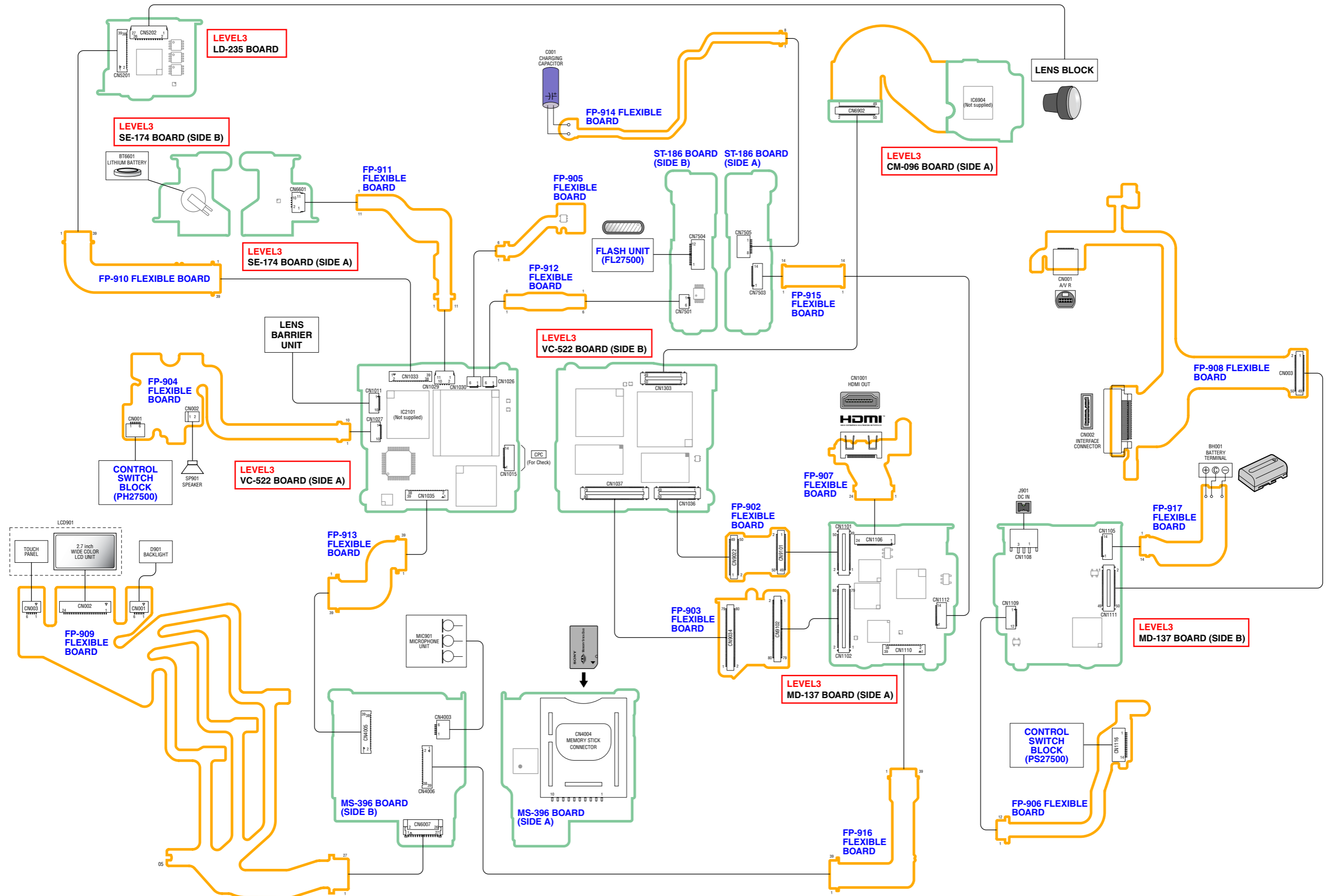

4-2. SCHEMATIC DIAGRAMS

Link

<ul style="list-style-type: none"> FP-910 FLEXIBLE BOARD (VC-LD CONNECTION) 	<ul style="list-style-type: none"> CONTROL SWITCH BLOCK (PH27500)
<ul style="list-style-type: none"> FP-911 FLEXIBLE BOARD (VC-SE CONNECTION) 	<ul style="list-style-type: none"> FP-905 FLEXIBLE BOARD (PANEL REVERSE DETECT)
<ul style="list-style-type: none"> FP-902 FLEXIBLE BOARD (VC-MD CONNECTION 1) 	<ul style="list-style-type: none"> FP-912 FLEXIBLE BOARD (VC-ST CONNECTION)
<ul style="list-style-type: none"> FP-903 FLEXIBLE BOARD (VC-MD CONNECTION 2) 	<ul style="list-style-type: none"> FP-915 FLEXIBLE BOARD (MD-ST CONNECTION)
<ul style="list-style-type: none"> FP-907 FLEXIBLE BOARD (HDMI CONNECTOR) 	<ul style="list-style-type: none"> ST-186 BOARD (1/2) (FLASH DRIVE)
<ul style="list-style-type: none"> FP-904 FLEXIBLE BOARD (CONTROL SWITCH) 	<ul style="list-style-type: none"> ST-186 BOARD (2/2) (CONNECTOR)
<ul style="list-style-type: none"> FP-913 FLEXIBLE BOARD (VC-MS CONNECTION) 	<ul style="list-style-type: none"> FLASH UNIT (FL27500)
<ul style="list-style-type: none"> FP-916 FLEXIBLE BOARD (MD-MS CONNECTION) 	<ul style="list-style-type: none"> FP-914 FLEXIBLE BOARD (CHARGING CAPACITOR)
<ul style="list-style-type: none"> MS-396 BOARD (1/2) (LCD DRIVE) 	<ul style="list-style-type: none"> CONTROL SWITCH BLOCK (PS27500)
<ul style="list-style-type: none"> MS-396 BOARD (2/2) (CONNECTOR) 	<ul style="list-style-type: none"> FP-906 FLEXIBLE BOARD (MD-PS CONNECTION)
<ul style="list-style-type: none"> FP-908 FLEXIBLE BOARD (AV/INTERFACE CONNECTOR) 	<ul style="list-style-type: none"> FP-917 FLEXIBLE BOARD (BATTERY TERMINAL)
<ul style="list-style-type: none"> FP-909 FLEXIBLE BOARD (LCD, BACKLIGHT) 	

• COMMON NOTE FOR SCHEMATIC DIAGRAMS

4-2. SCHEMATIC DIAGRAMS
(ENGLISH)

THIS NOTE IS COMMON FOR SCHEMATIC DIAGRAMS
(In addition to this, the necessary note is printed in each block)

(For schematic diagrams)

- All capacitors are in μF unless otherwise noted. $\text{pF} : \mu\text{F}$. 50 V or less are not indicated except for electrolytics and tantalums.
- Chip resistors are 1/10 W unless otherwise noted. $\text{k}\Omega=1000 \Omega$, $\text{M}\Omega=1000 \text{k}\Omega$.
- Caution when replacing chip parts.
New parts must be attached after removal of chip.
Be careful not to heat the minus side of tantalum capacitor, Because it is damaged by the heat.
- Some chip part will be indicated as follows.

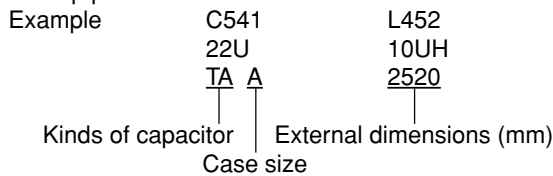

- Constants of resistors, capacitors, ICs and etc with XX indicate that they are not used.
In such cases, the unused circuits may be indicated.
- Parts with \star differ according to the model/destination. Refer to the mount table for each function.
- All variable and adjustable resistors have characteristic curve B, unless otherwise noted.
- Signal name
XEDIT \rightarrow EDIT PB/XREC \rightarrow PB/REC
- : non flammable resistor
- : fusible resistor
- : panel designation
- : B+ Line
- : B- Line
- : IN/OUT direction of (+,-) B LINE.
- : adjustment for repair.

(Measuring conditions voltage and waveform)

- Voltages and waveforms are measured between the measurement points and ground when camera shoots color bar chart of pattern box. They are reference values and reference waveforms.
(VOM of DC 10 $\text{M}\Omega$ input impedance is used)
- Voltage values change depending upon input impedance of VOM used.)

Precautions for Replacement of Imager

- If the imager has been replaced, carry out all the adjustments for the camera section.
- As the imager may be damaged by static electricity from its structure, handle it carefully like for the MOS IC.
In addition, ensure that the receiver is not covered with dusts nor exposed to strong light.

1. Connection

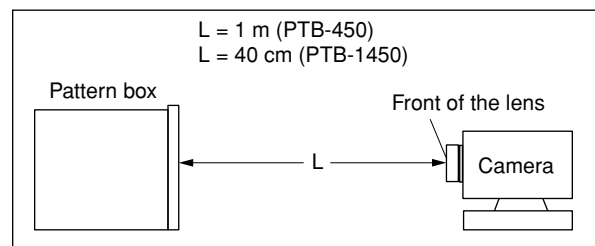
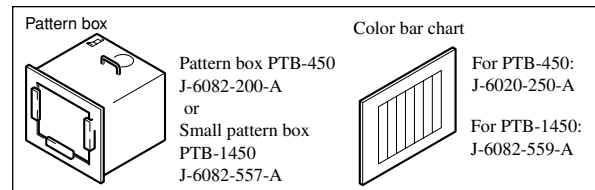

2. Adjust the distance so that the output waveform of Fig. a and the Fig. b can be obtain.

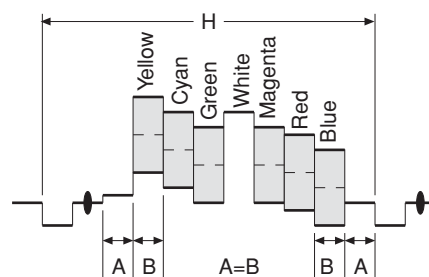

Fig. a (Video output terminal output waveform)

Electronic beam scanning frame

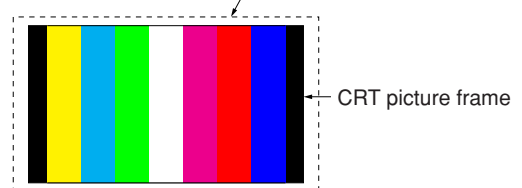

Fig.b (Picture on monitor TV)

When indicating parts by reference number, please include the board name.

The components identified by mark \triangle or dotted line with mark \triangle are critical for safety.
Replace only with part number specified.

Les composants identifiés par une marque \triangle sont critiques pour la sécurité.
Ne les remplacer que par une pièce portant le numéro spécifique.

(JAPANESE)

回路図共通ノート







(他に必要なノートは各ブロックに記載してあります)

【回路図ノート】

- ・ケミコン、タンタルを除くコンデンサで、耐圧50V以下のものはその耐圧を省略。単位はすべて μF (pはpF)。
- ・チップ抵抗で指示のないものは、 $1/10\text{W}$ 以下。
 $k\Omega=1000\Omega$, $M\Omega=1000k\Omega$
- ・チップ部品交換時の注意
取り外した部品は再使用せず、未使用の部品をご使用ください。
- ・タンタルコンデンサのマイナス側は熱に弱いので注意してください。

- ・チップ部品には下記のように表示したものがああります。

例	C 541	L 452
	22U	10UH
	TA A	2520
	↑ ↑	↑
	種類 ケースサイズ	外形寸法 (mm)

- ・抵抗、コンデンサ、ICなど定数にXXがあるものは、使用していない事を示しています。このため、使用していない回路が記載されている事があります。
- ・★印のある部品は、機種などにより異なりますので機能別マウント一覧表を参照してください。
- ・可変抵抗と半固定抵抗で、B特性の表示を省略。
- ・信号名表記について、下記のような場合があります。
XEDIT → EDIT PB/XREC → PB/REC
- ・ は不燃性抵抗。
- ・ はヒューズ抵抗。
- ・ はパネル表示名称。
- ・ はB+ライン。
- ・ はB-ライン。
- ・ はBライン (+, -) の入出力方向を示す。
- ・ は調整名称。

【電圧・波形測定条件ノート】

- ・電圧値及び信号波形はパターンボックスのカラーバーチャートを被写体としたときの測定点対アース間の参考値。
(デジタルマルチメータ; 入力インピーダンス DC10M Ω 使用)
- ・使用テスタの入力インピーダンスにより電圧値が多少異なります。

イメージ交換時の注意

- ・イメージを交換した場合は、カメラ部の全調整を行ってください。
- ・イメージは構造上、静電気により破壊される恐れがあるため、MOS ICと同様に注意して取り扱ってください。
また、受光部にはゴミの付着、および強い光がはいることのないように注意してください。

1. 接続図

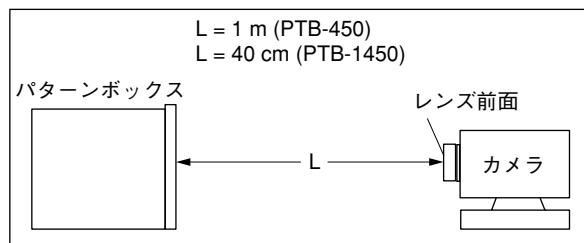
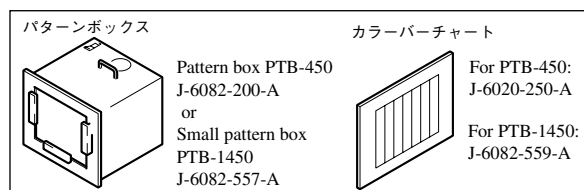

- 2. 図a及び図bの波形が得られるように画枠調整して下さい。

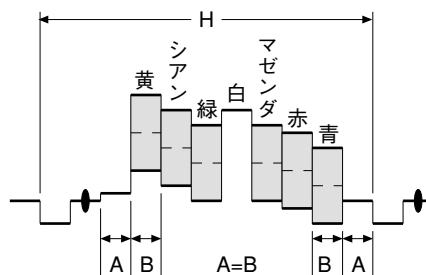

図a (映像入出力端子出力波形)

電子ビーム走査線

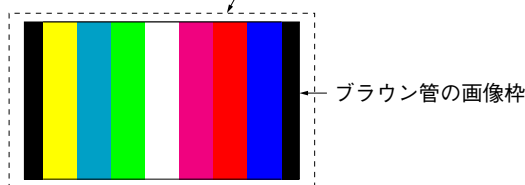

図b (テレビモニタの映像)

△印の部品、または△印付きの点線で囲まれた部品は、安全性を維持するために重要な部品です。従って交換時は、必ず指定の部品を使用して下さい。

お願い
図面番号で部品を指定するときは基板名又はブロックを併せて指定して下さい。

Schematic diagrams of the CM-096, LD-235 and SE-174 boards are not shown.
Pages from 4-4 to 4-6 are not shown.

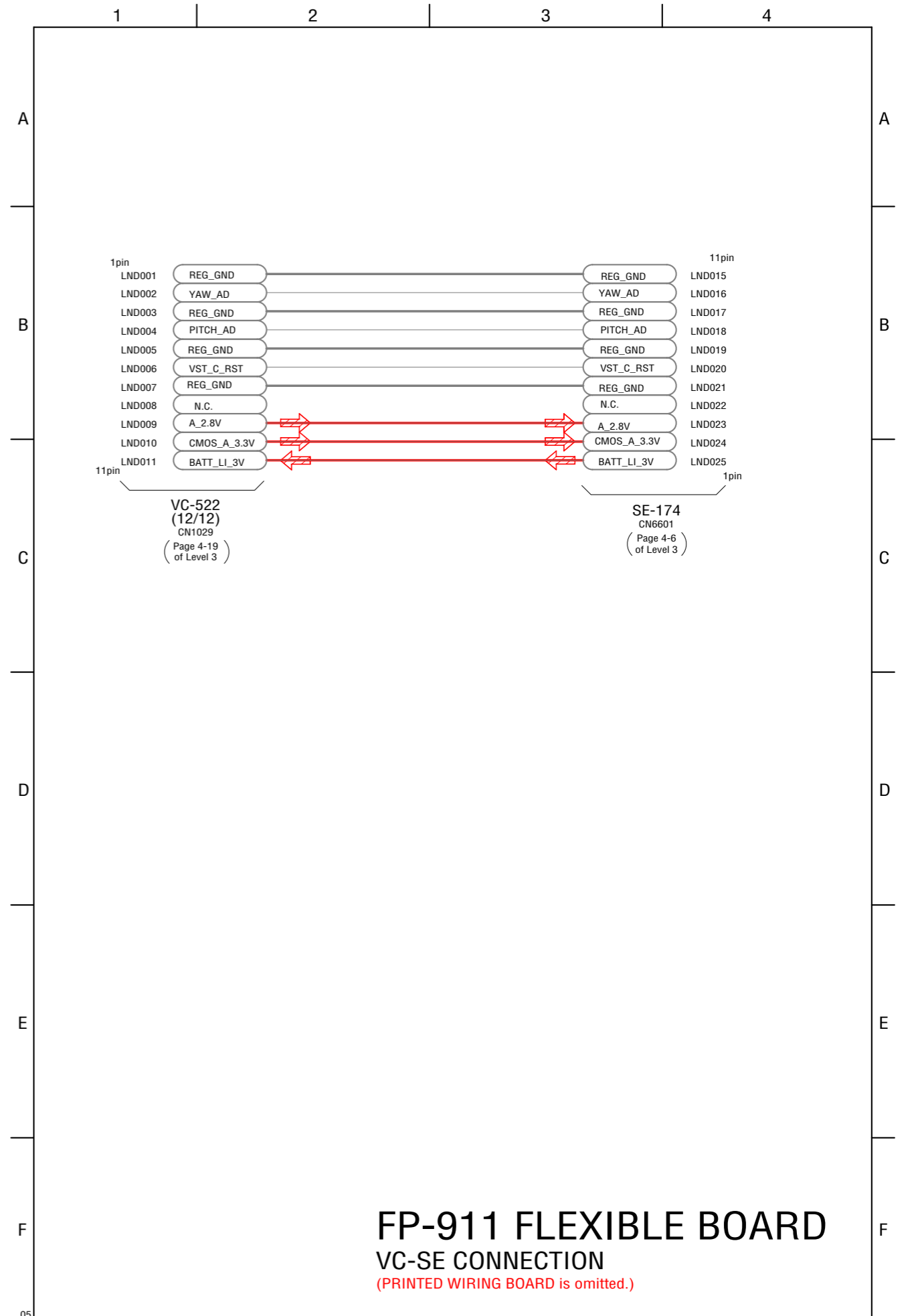
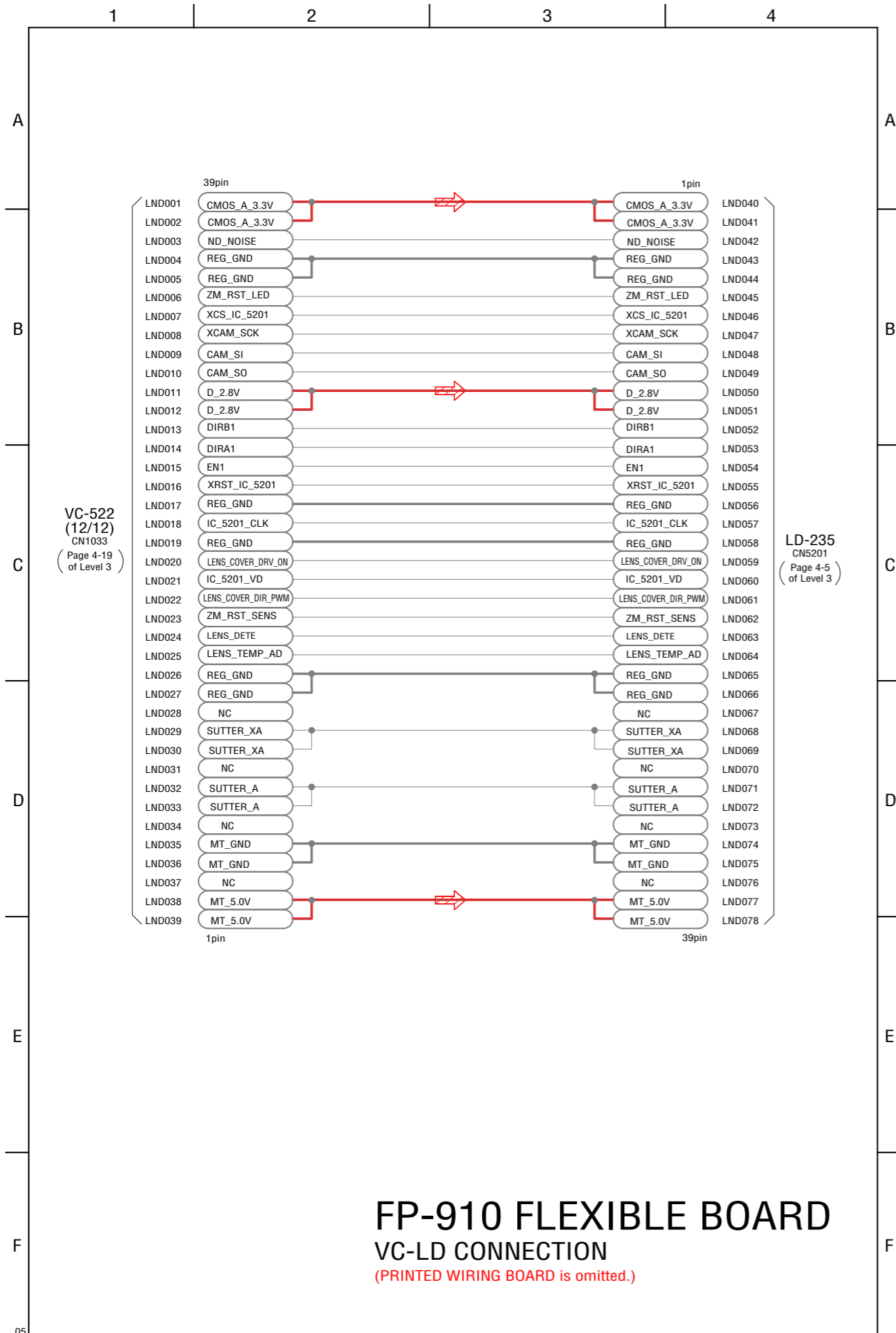

Schematic diagrams of the VC-522 board is not shown.
Pages from 4-8 to 4-19 are not shown.

A

B

C

D

E

F

G

H

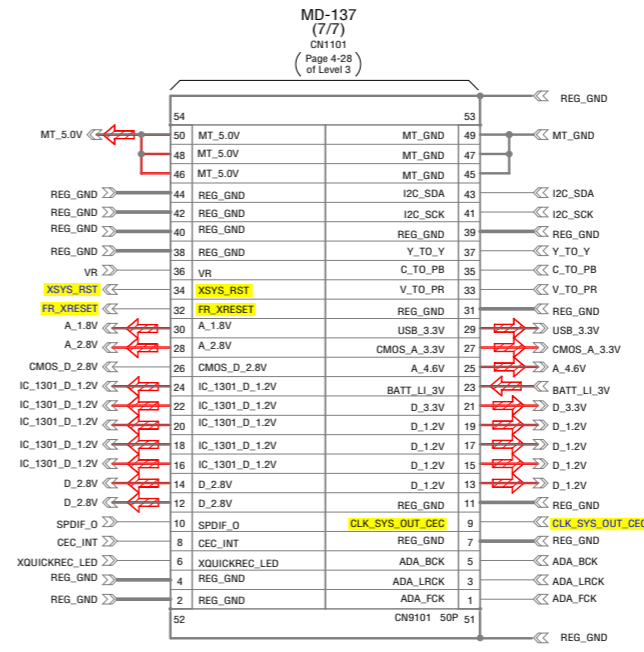
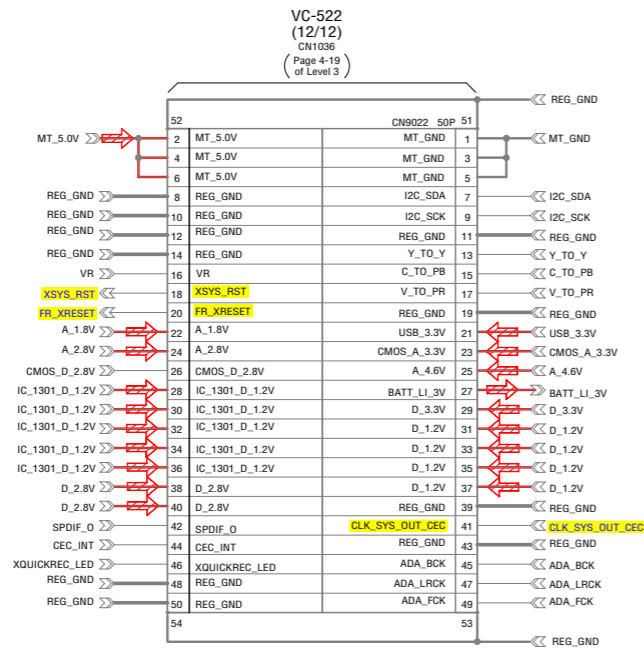

A

B

C

D

E

F

G

H

FP-902 FLEXIBLE BOARD
VC-MD CONNECTION 1



FP-903 FLEXIBLE BOARD
VC-MD CONNECTION 2

Schematic diagrams of the MD-137 board is not shown.
Pages from 4-22 to 4-28 are not shown.

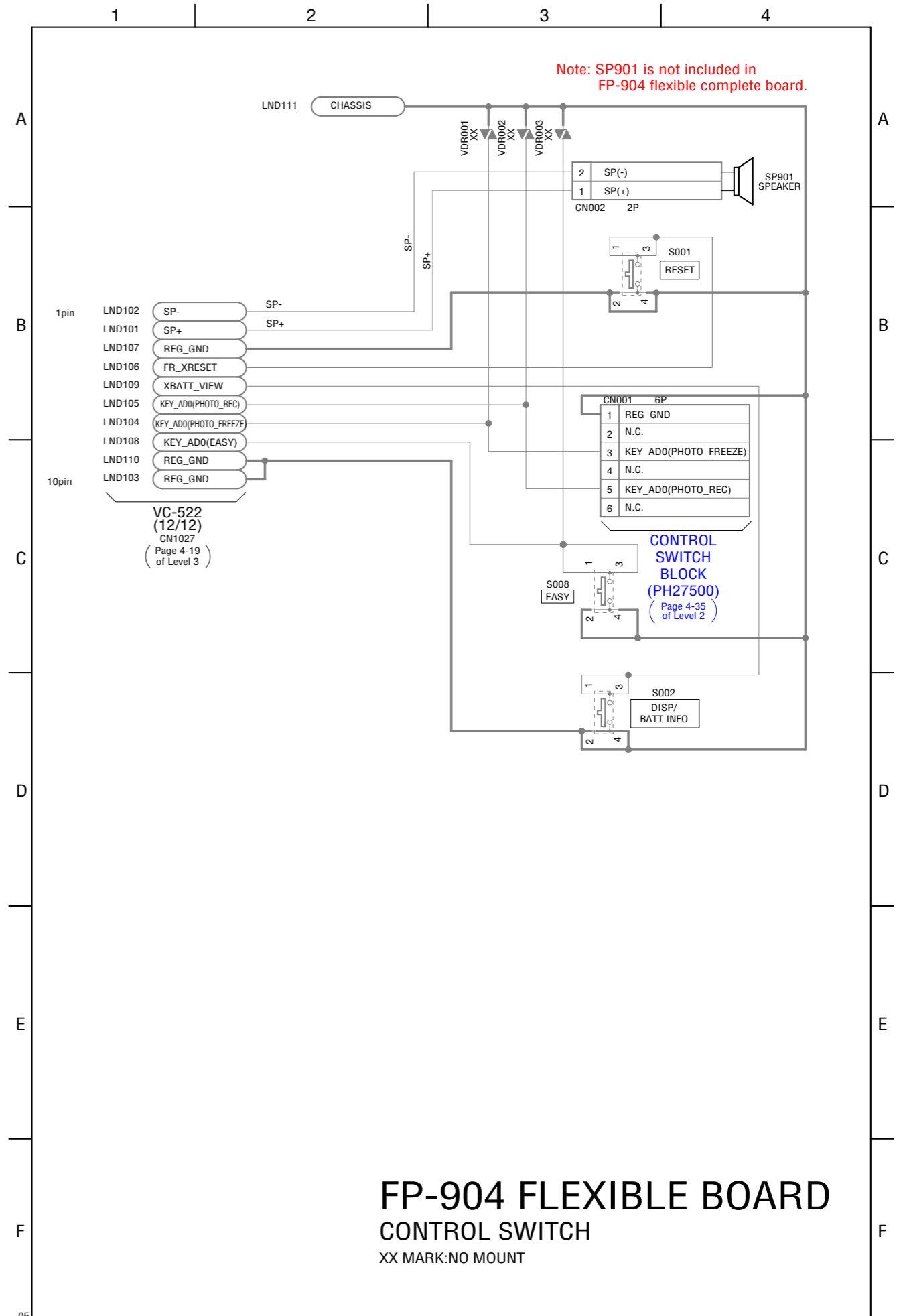
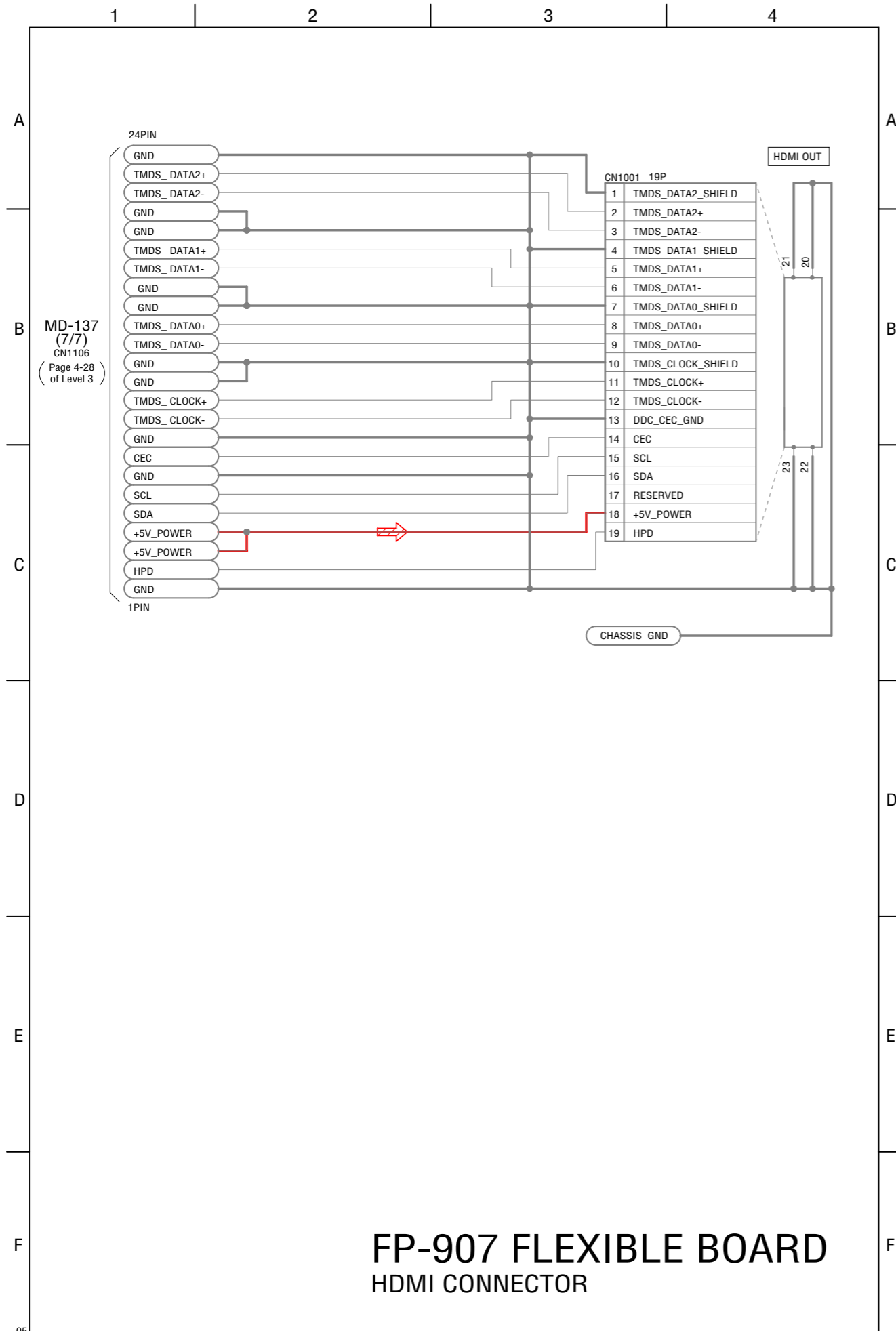

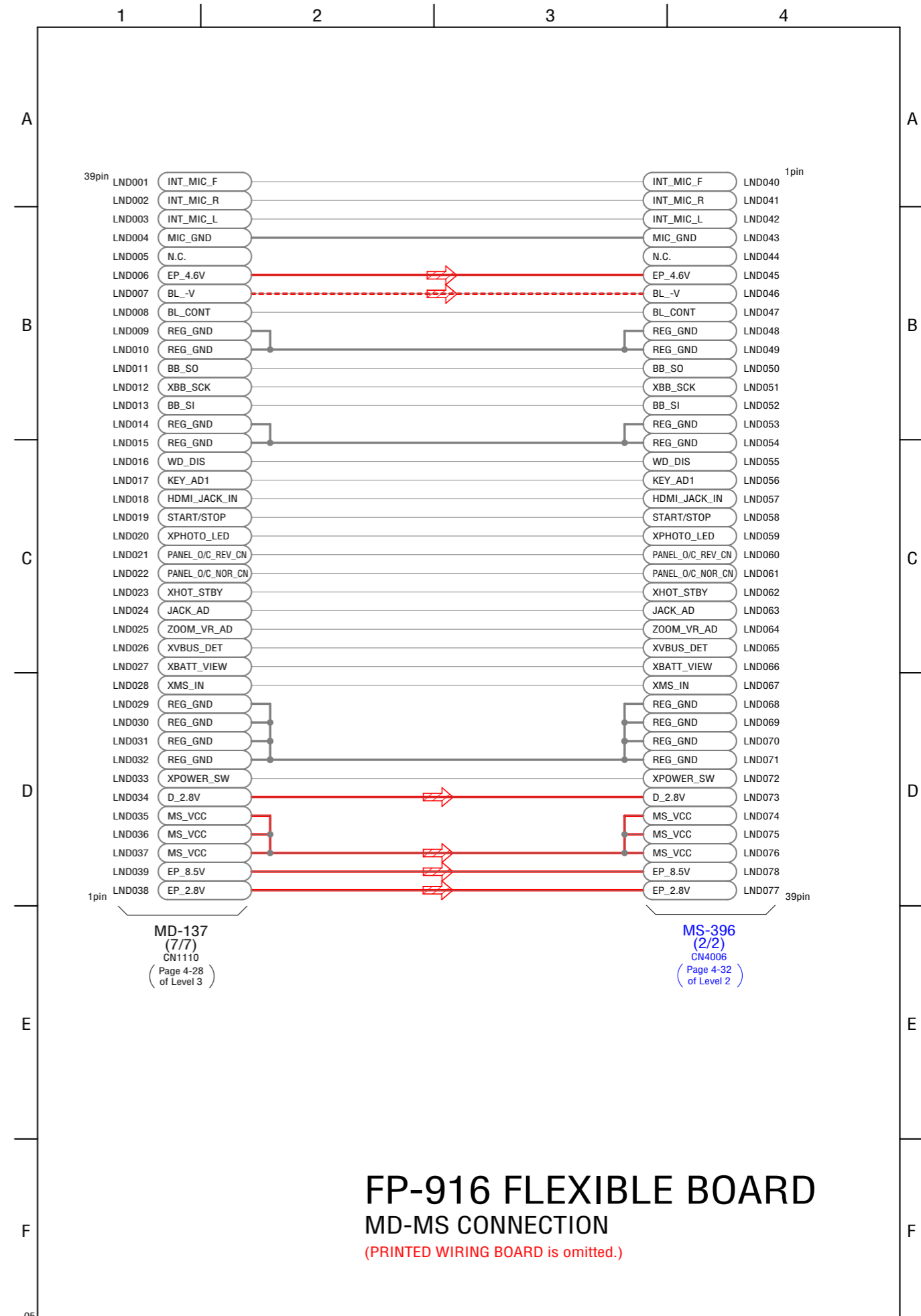
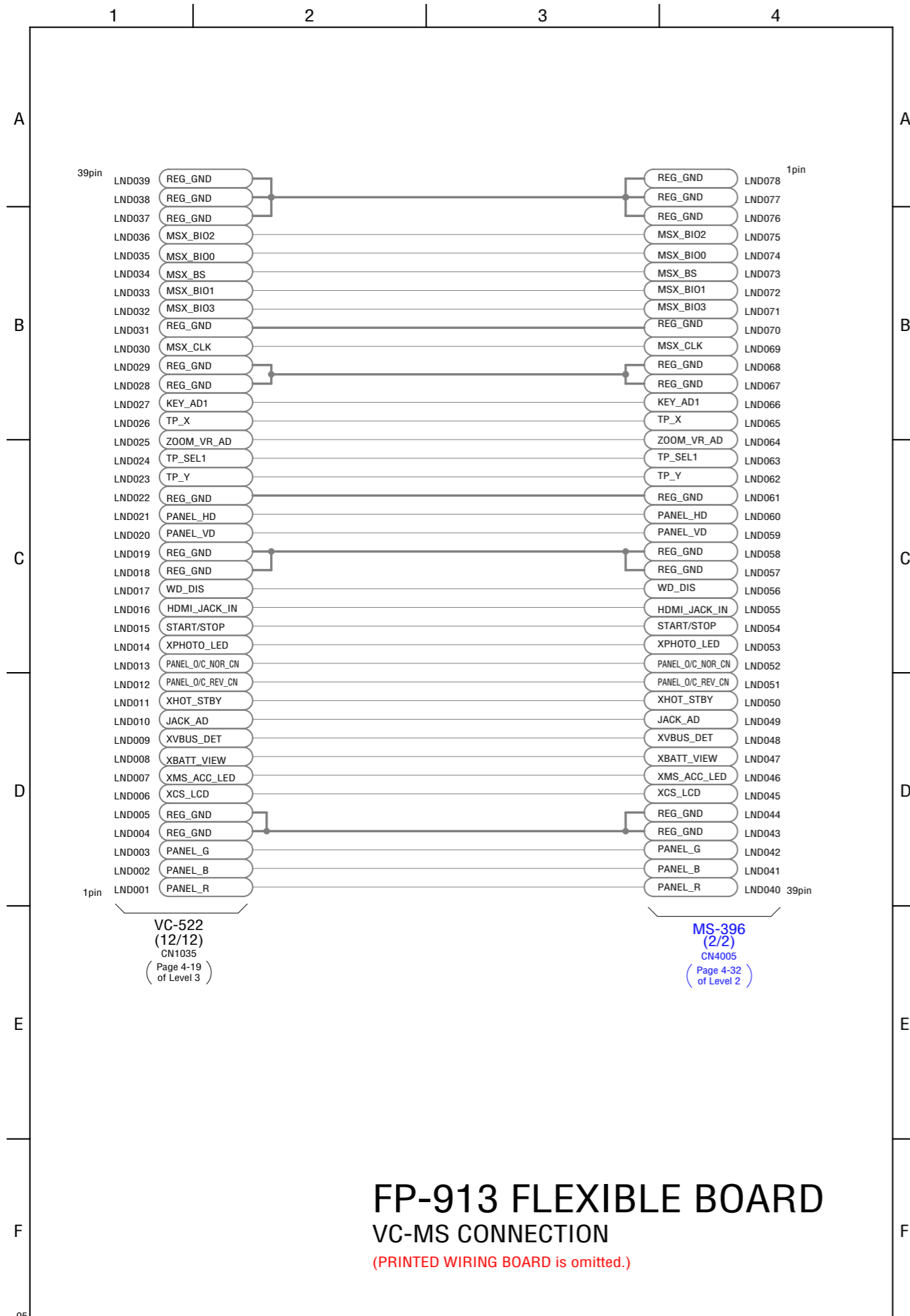

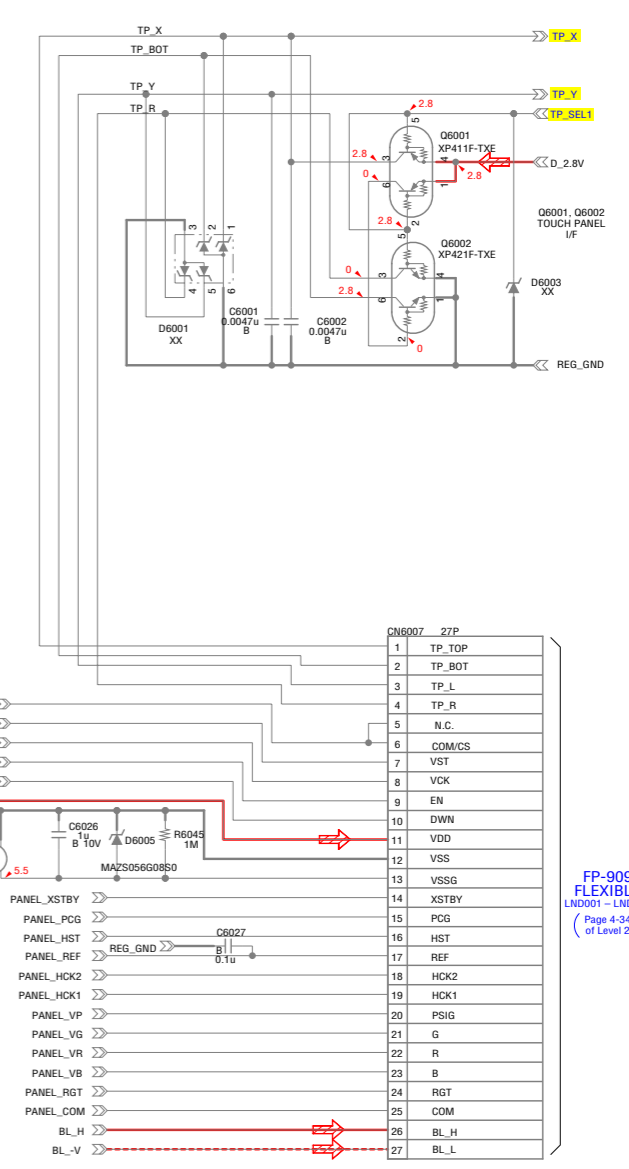
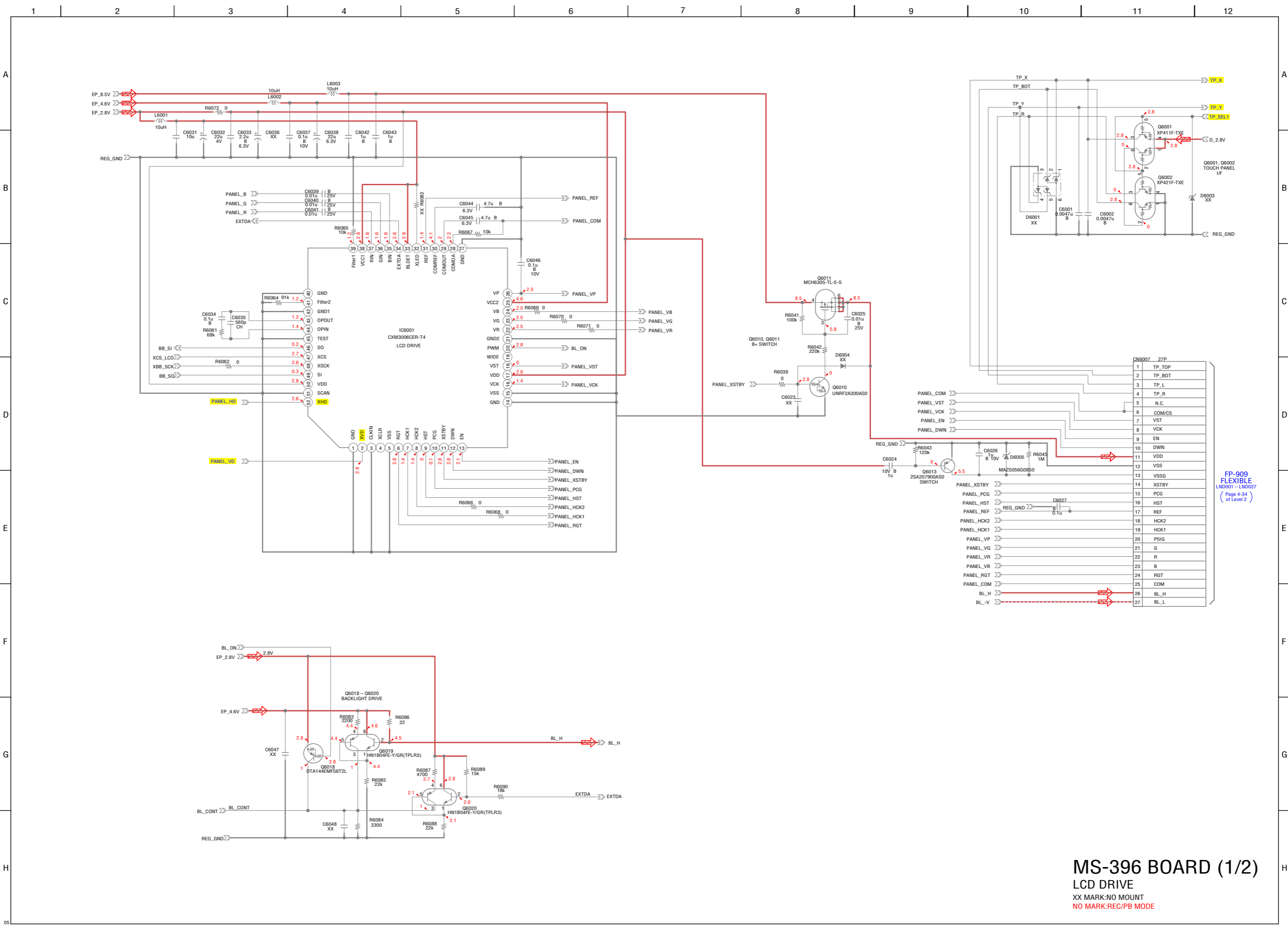

Pin	Signal
1	TP_TOP
2	TP_BOT
3	TP_L
4	TP_R
5	N.C.
6	COM/CS
7	VST
8	VCK
9	EN
10	DWN
11	VDD
12	VSS
13	VSSG
14	XSTBY
15	PCG
16	HST
17	REF
18	HCK2
19	HCK1
20	PSIG
21	G
22	R
23	B
24	RG
25	COM
26	BL_H
27	BL_L

FP-909 FLEXIBLE LND001 - LND027 (Page 4-34 of Level 2)

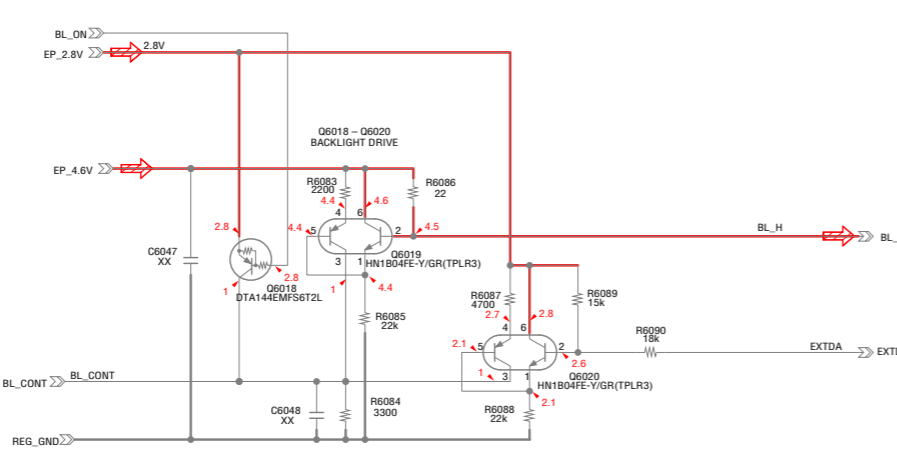

MS-396 BOARD (1/2)
 LCD DRIVE
 XX MARK:NO MOUNT
 NO MARK:REC/PB MODE

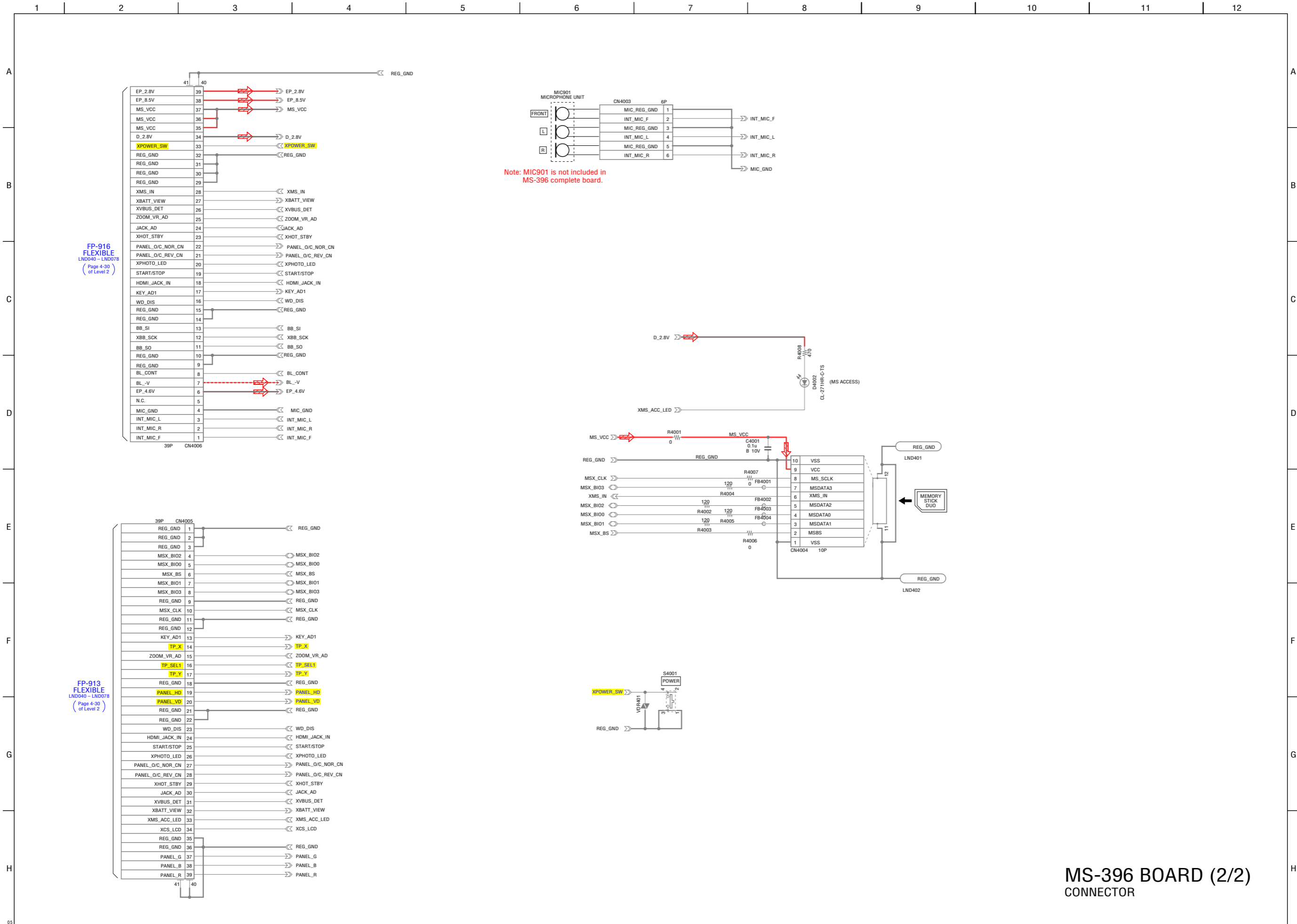

FP-916
FLEXIBLE
LND040 - LND078
(Page 4-30
of Level 2)

FP-913
FLEXIBLE
LND040 - LND078
(Page 4-30
of Level 2)

MS-396 BOARD (2/2) CONNECTOR

• Refer to page 4-2 (English), 4-3 (Japanese) for mark Δ .

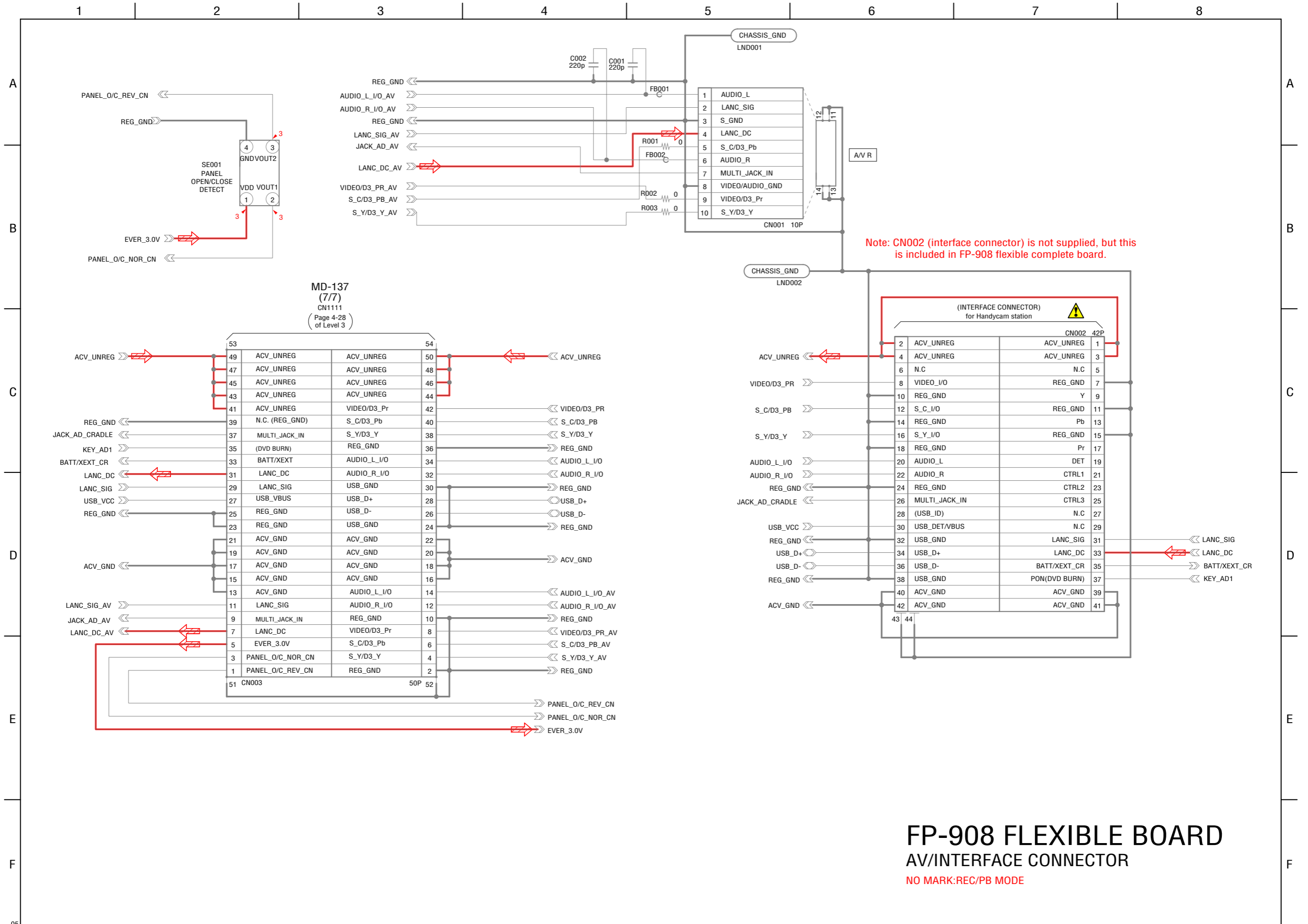

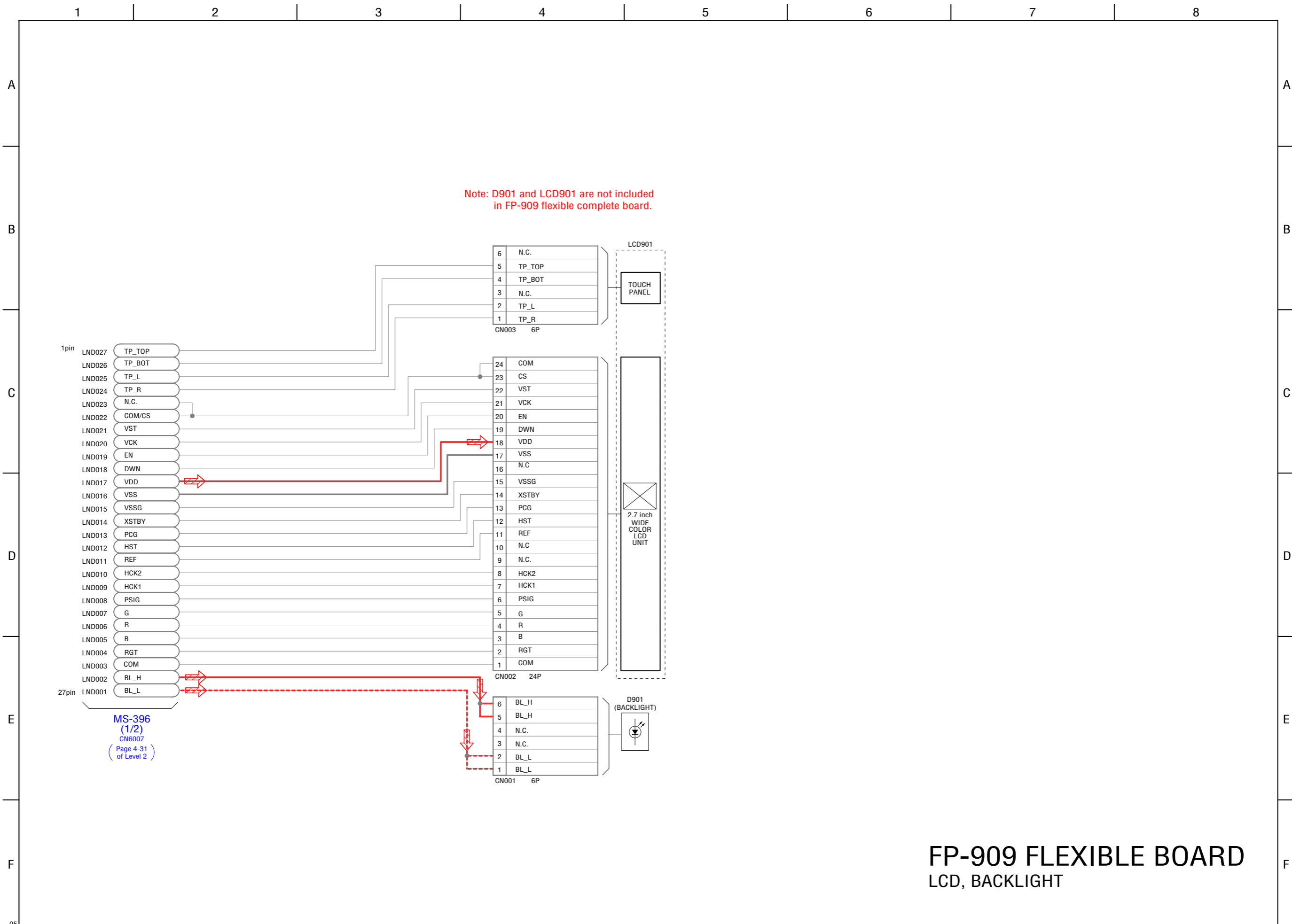

FP-909 FLEXIBLE BOARD

LCD, BACKLIGHT

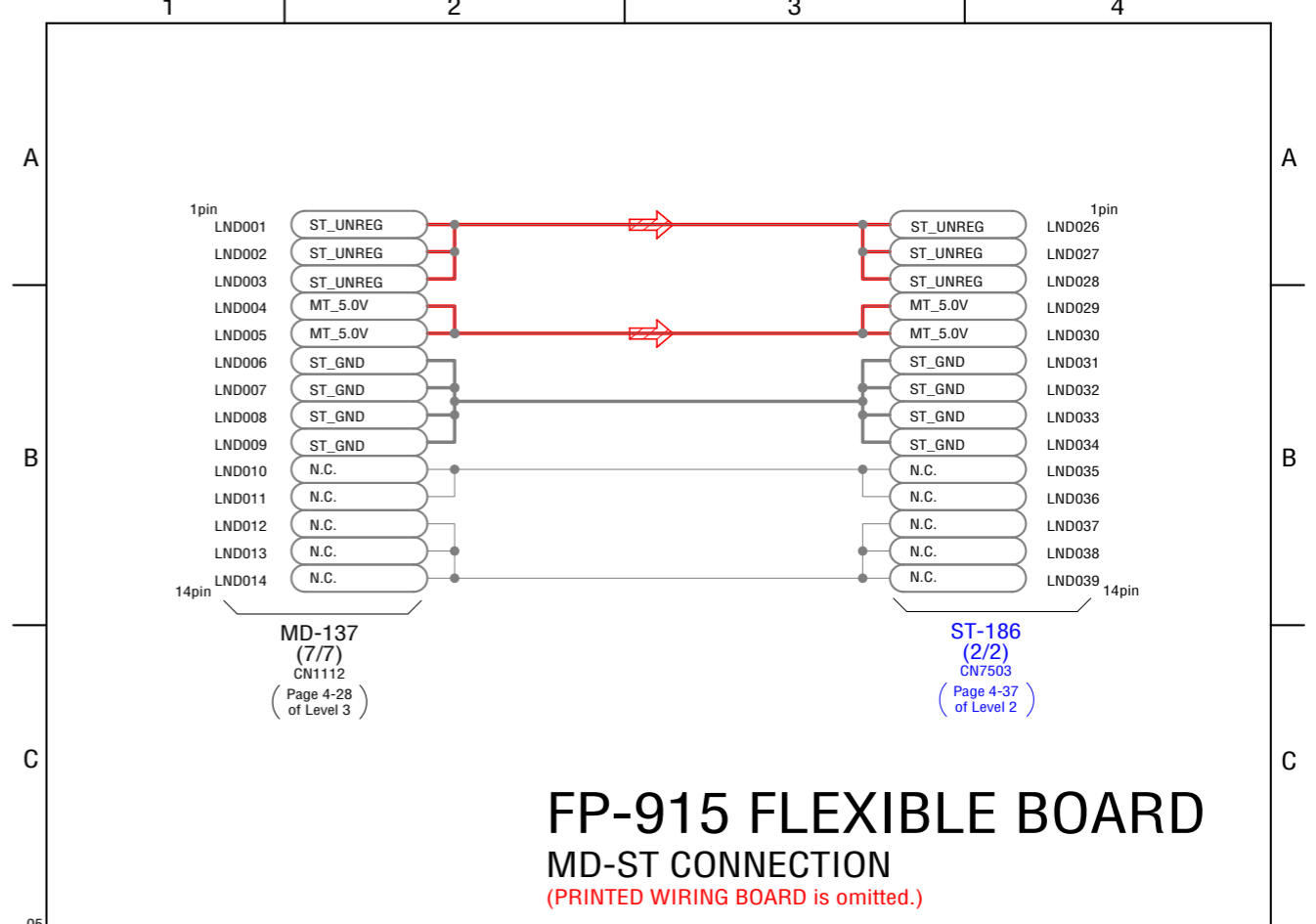
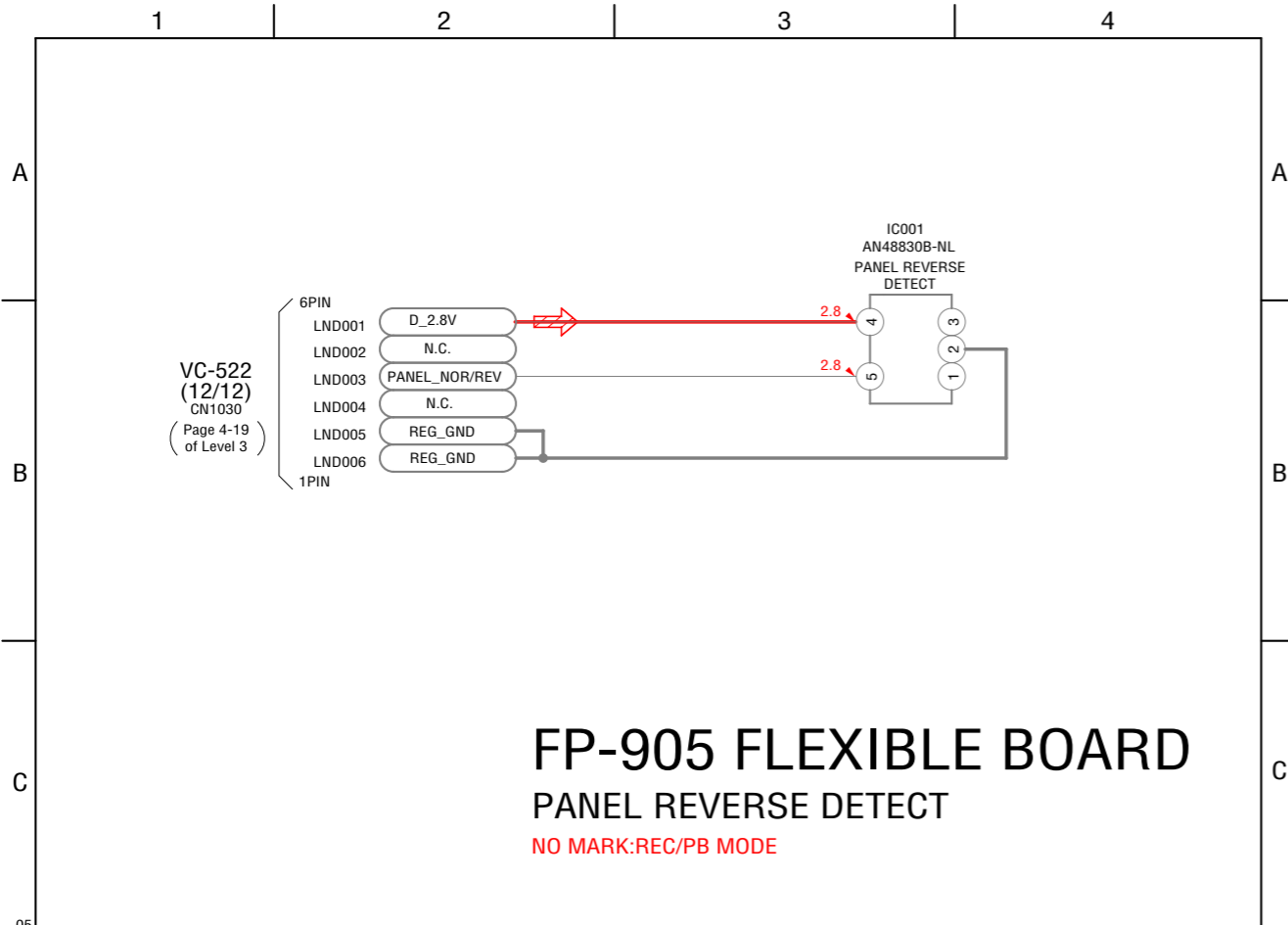
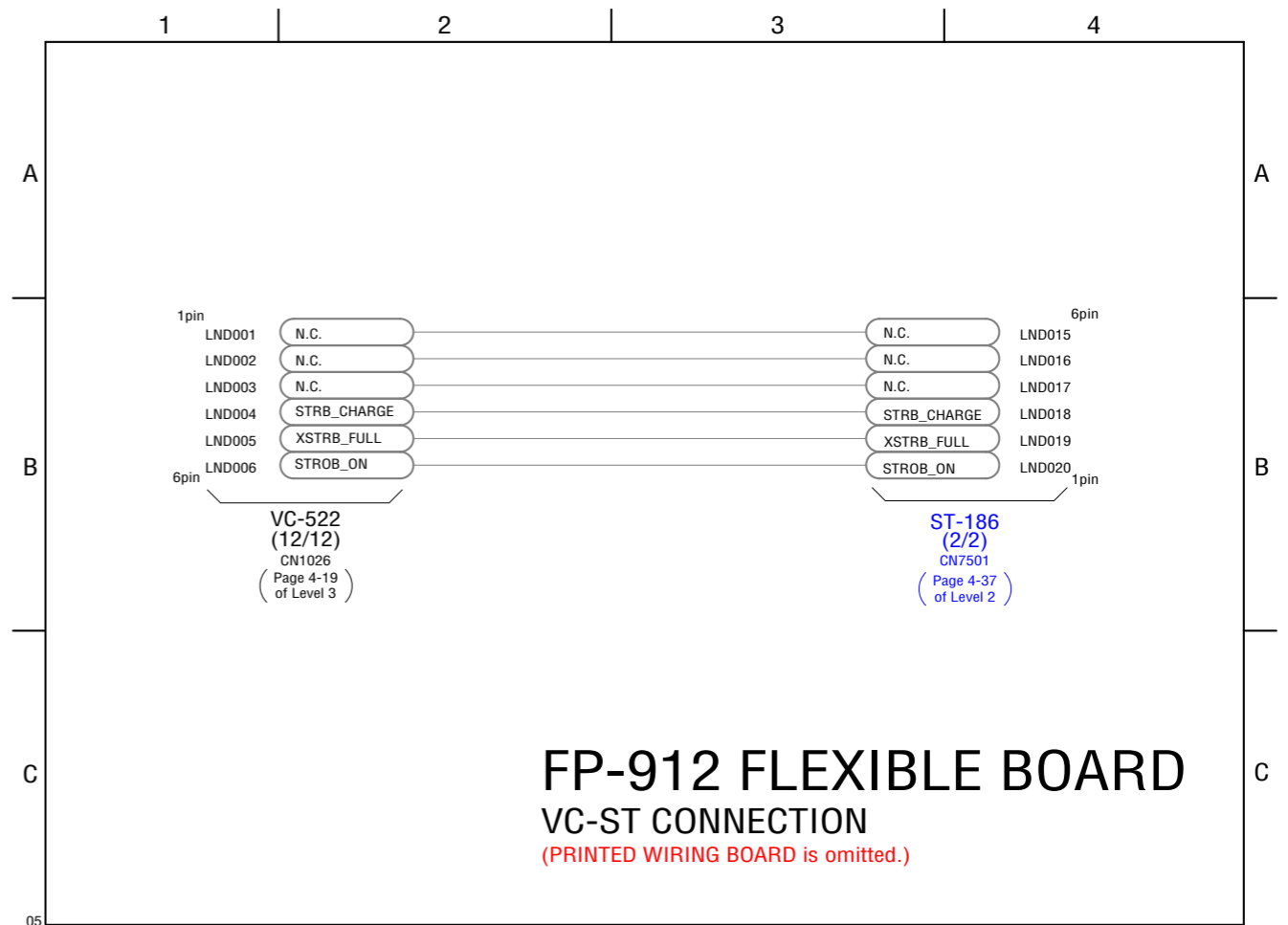
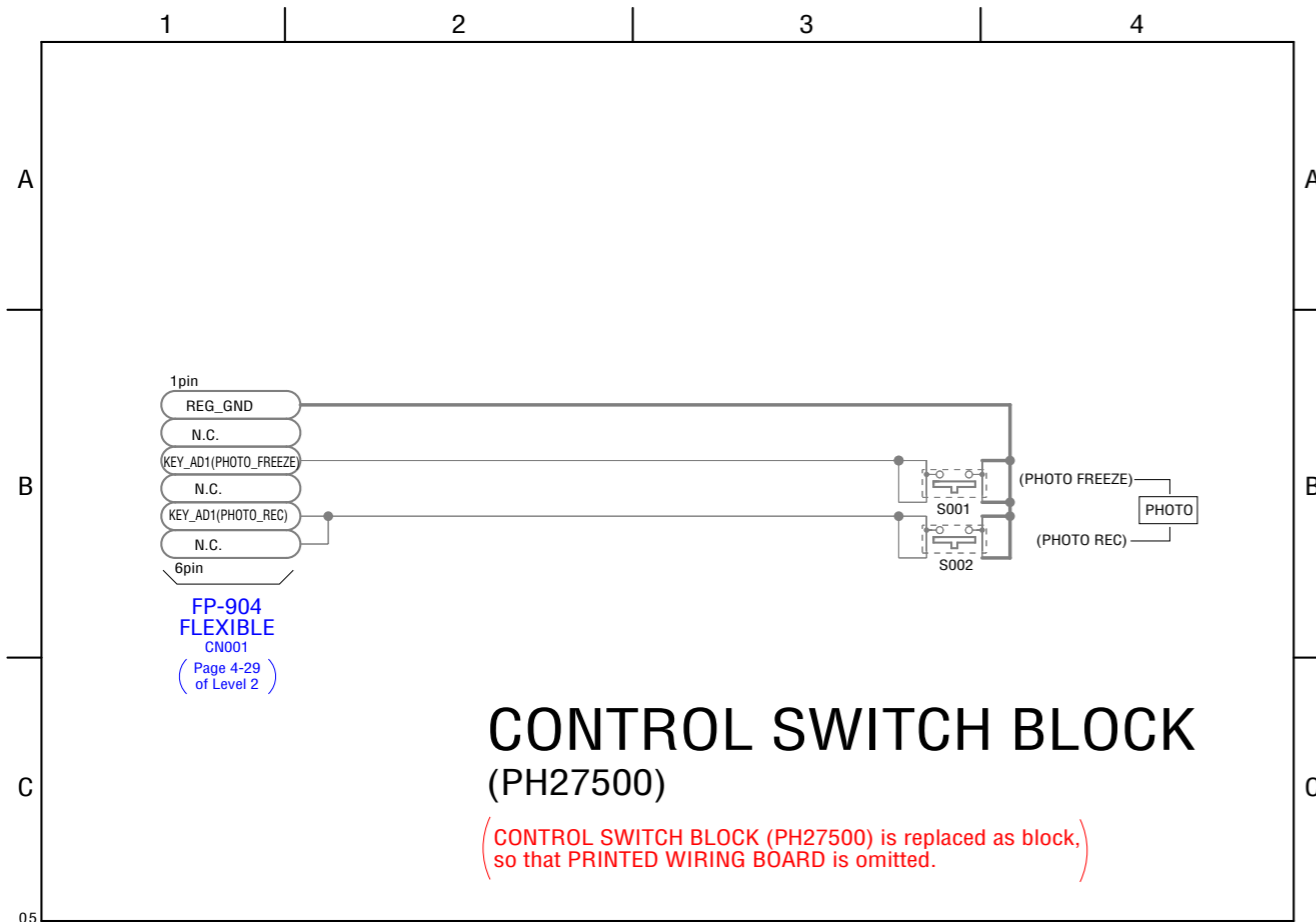

• Refer to page 4-2 (English), 4-3 (Japanese) for mark △.

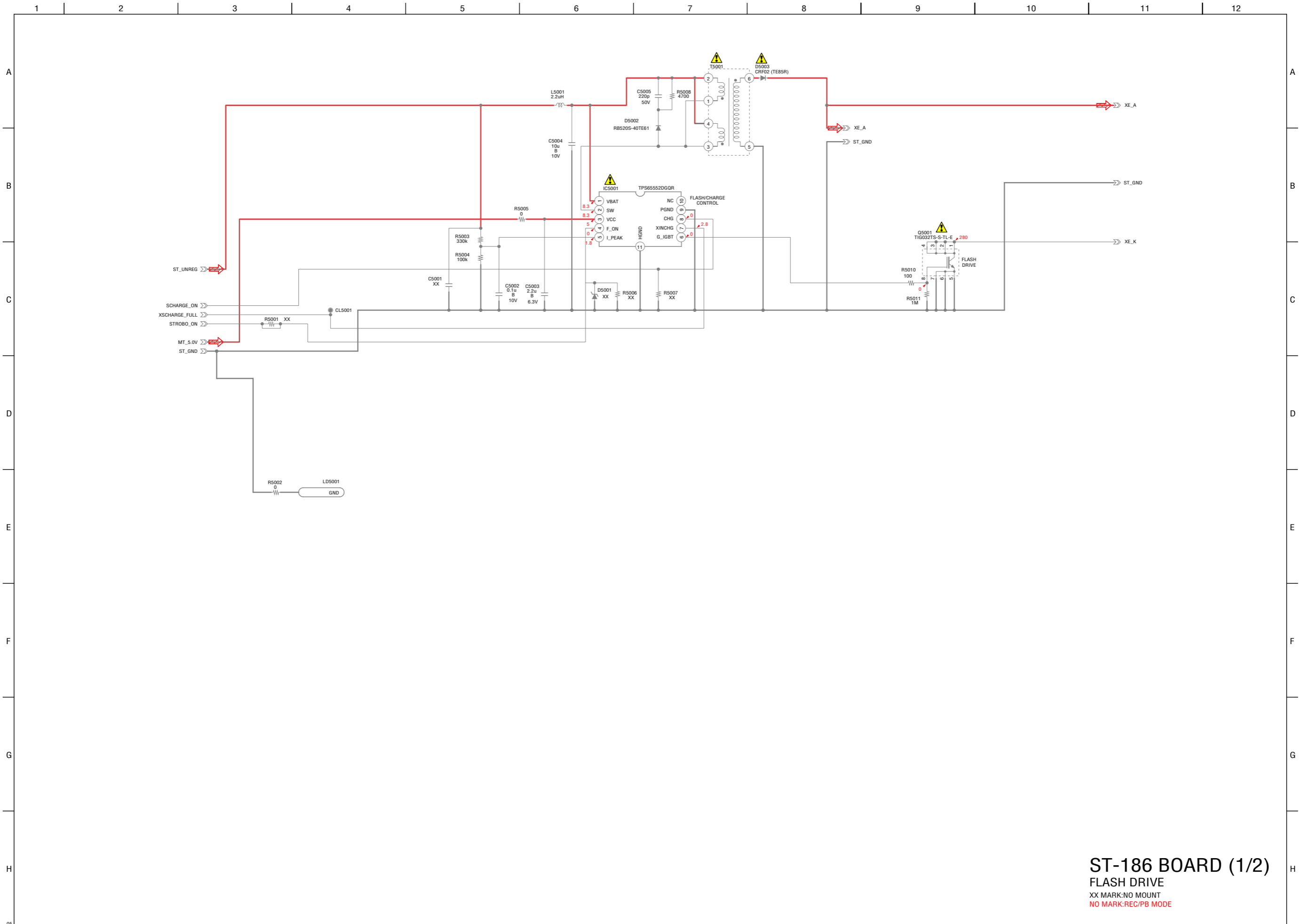

ST-186 BOARD (1/2)
FLASH DRIVE
XX MARK:NO MOUNT
NO MARK:REC/PB MODE

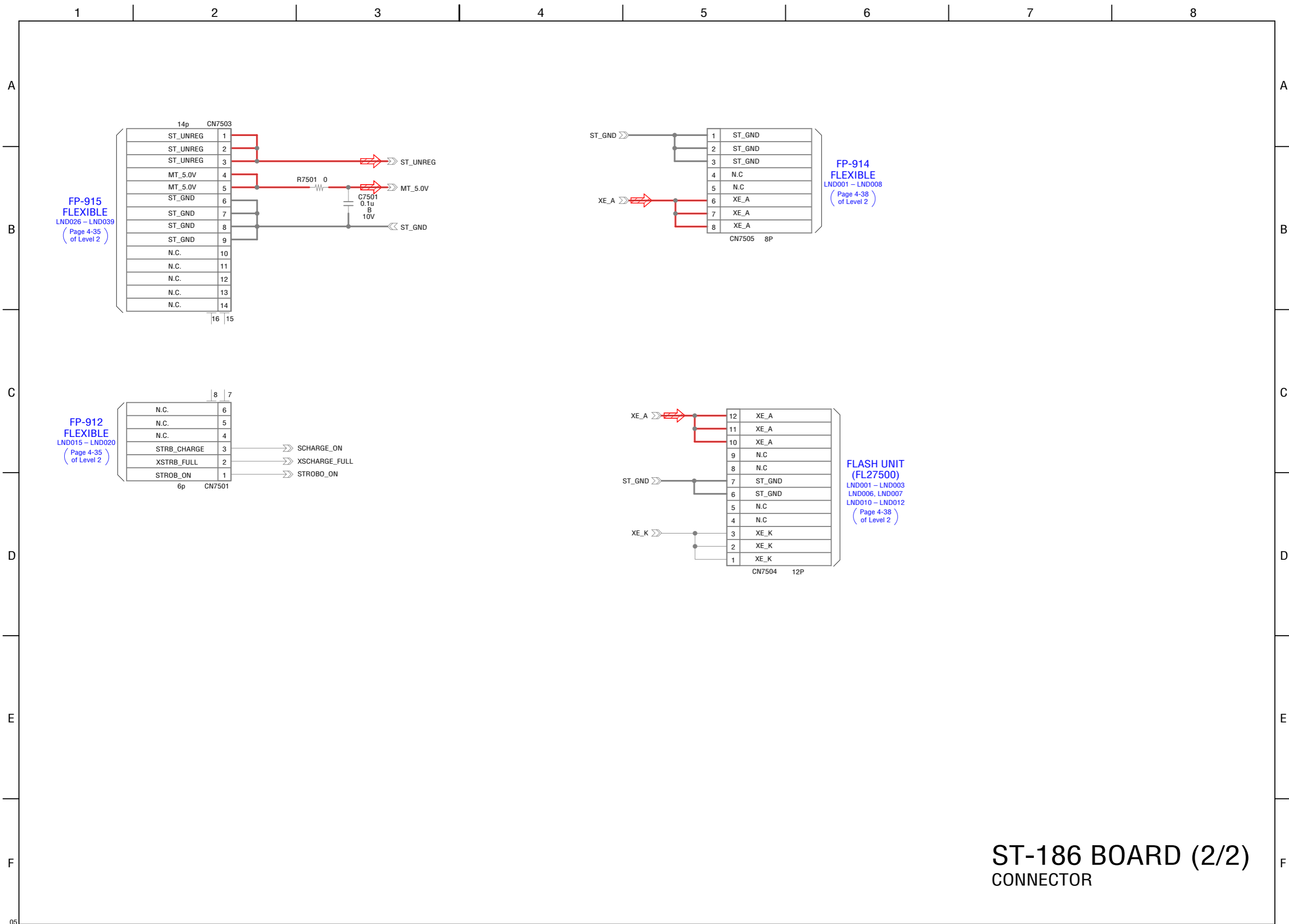

ST-186 BOARD (2/2)
CONNECTOR

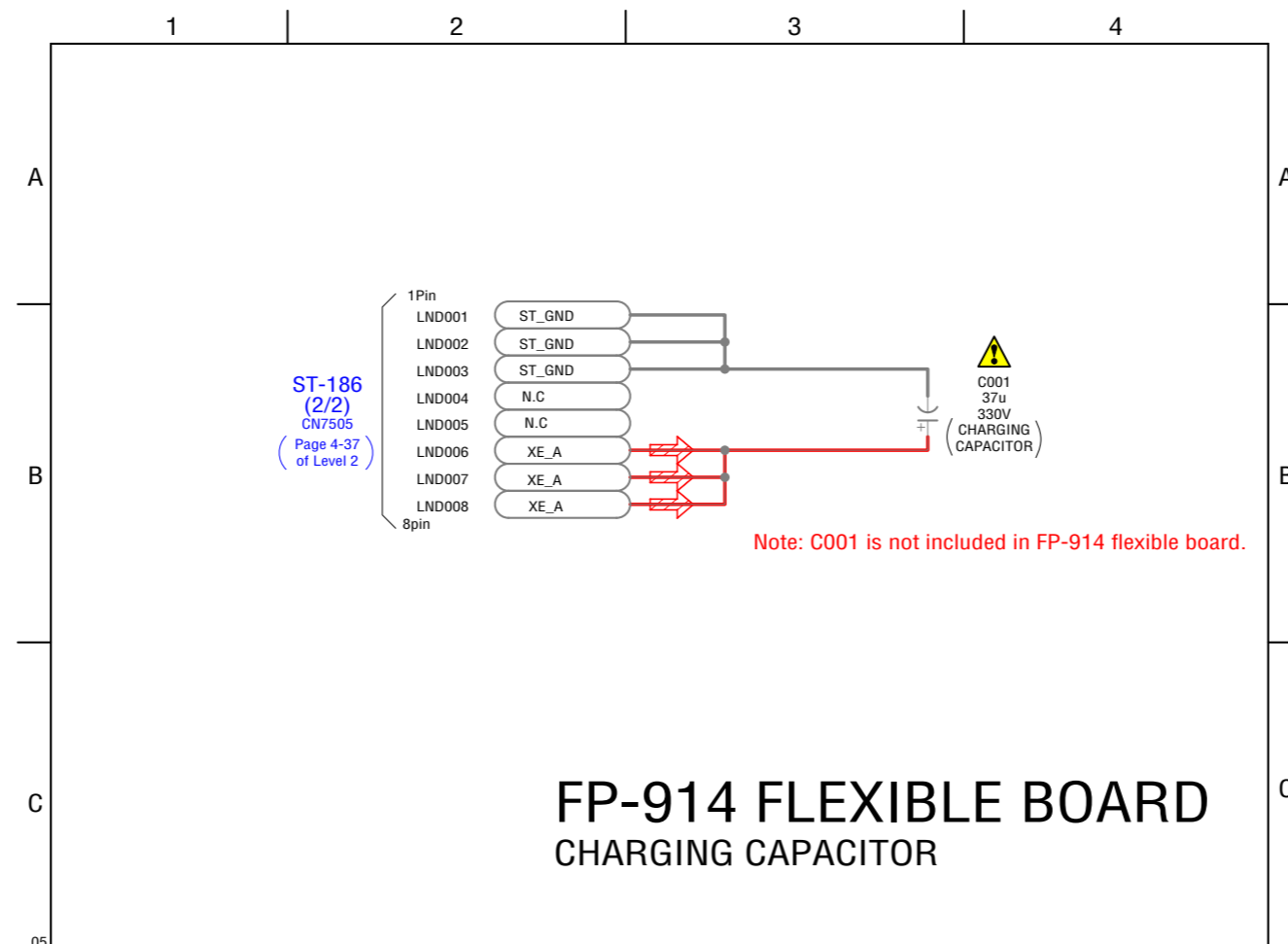
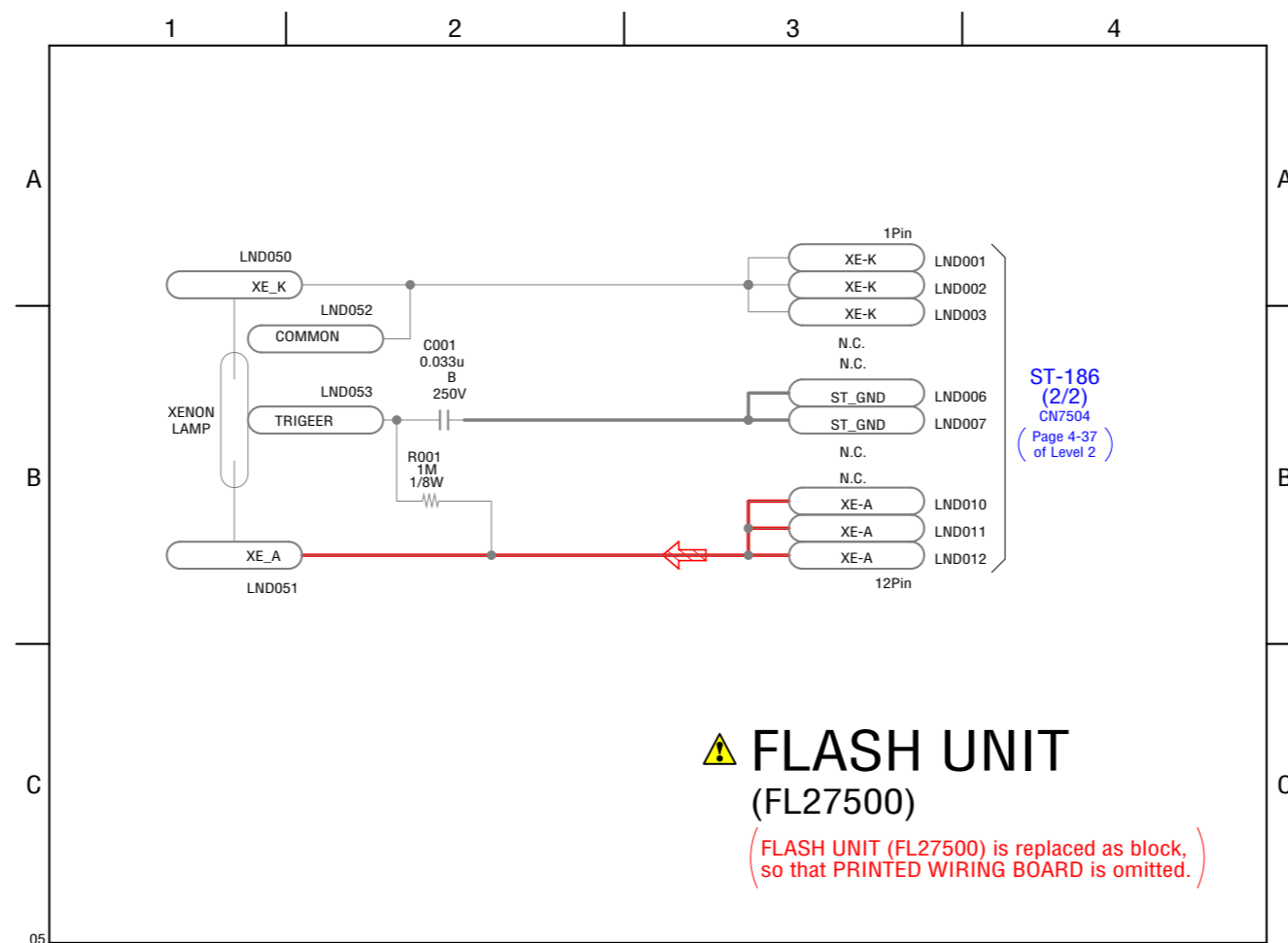

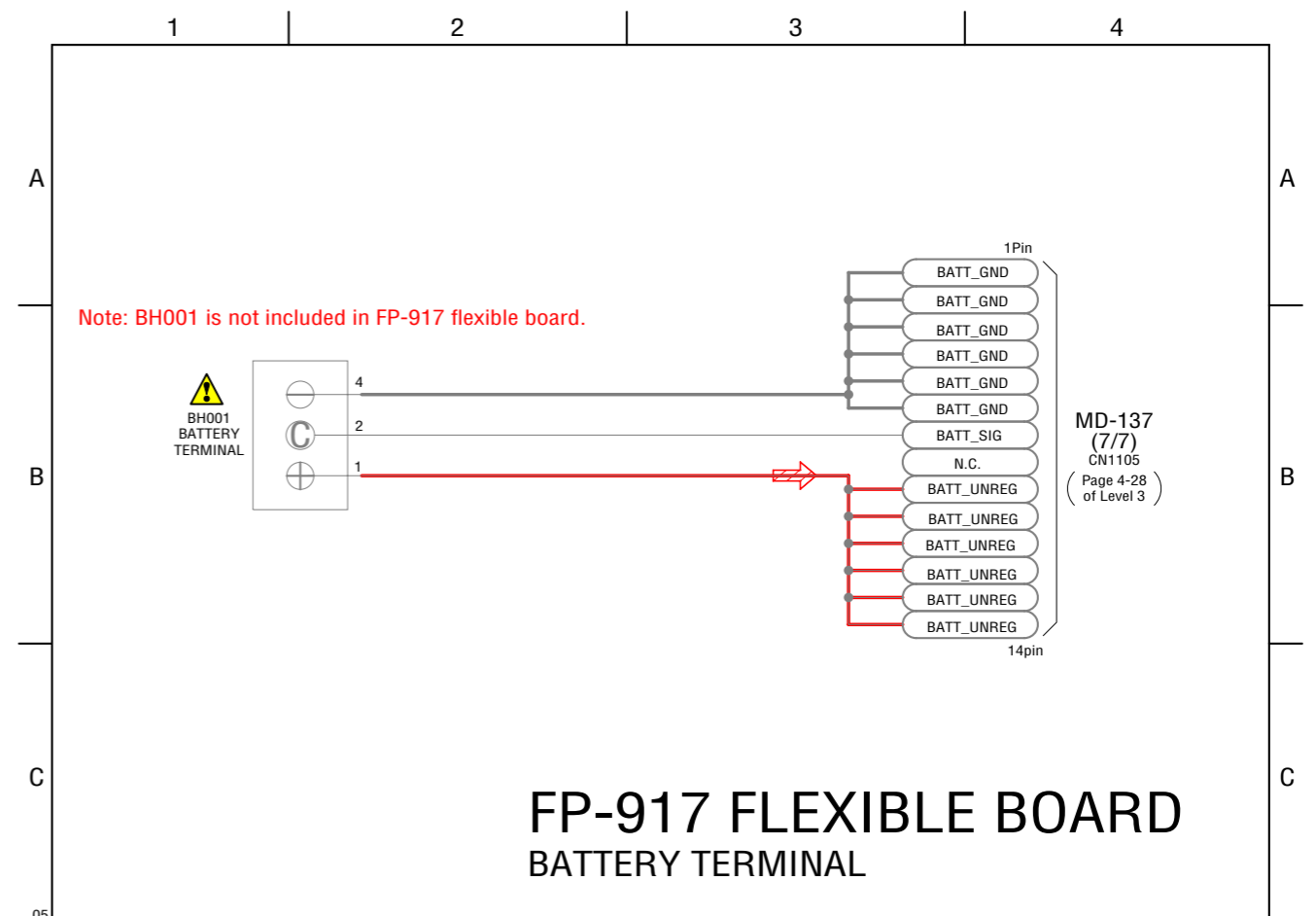
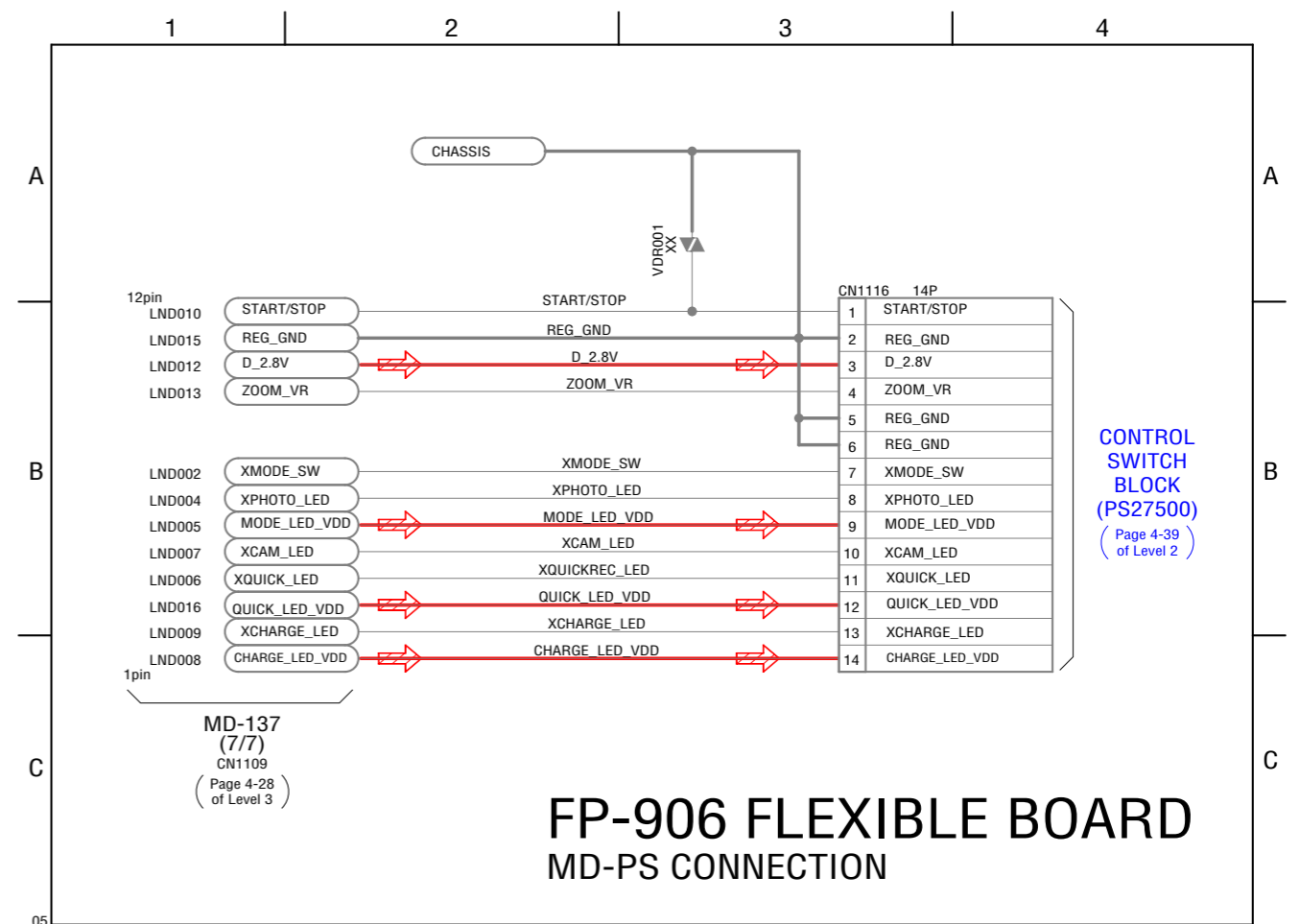
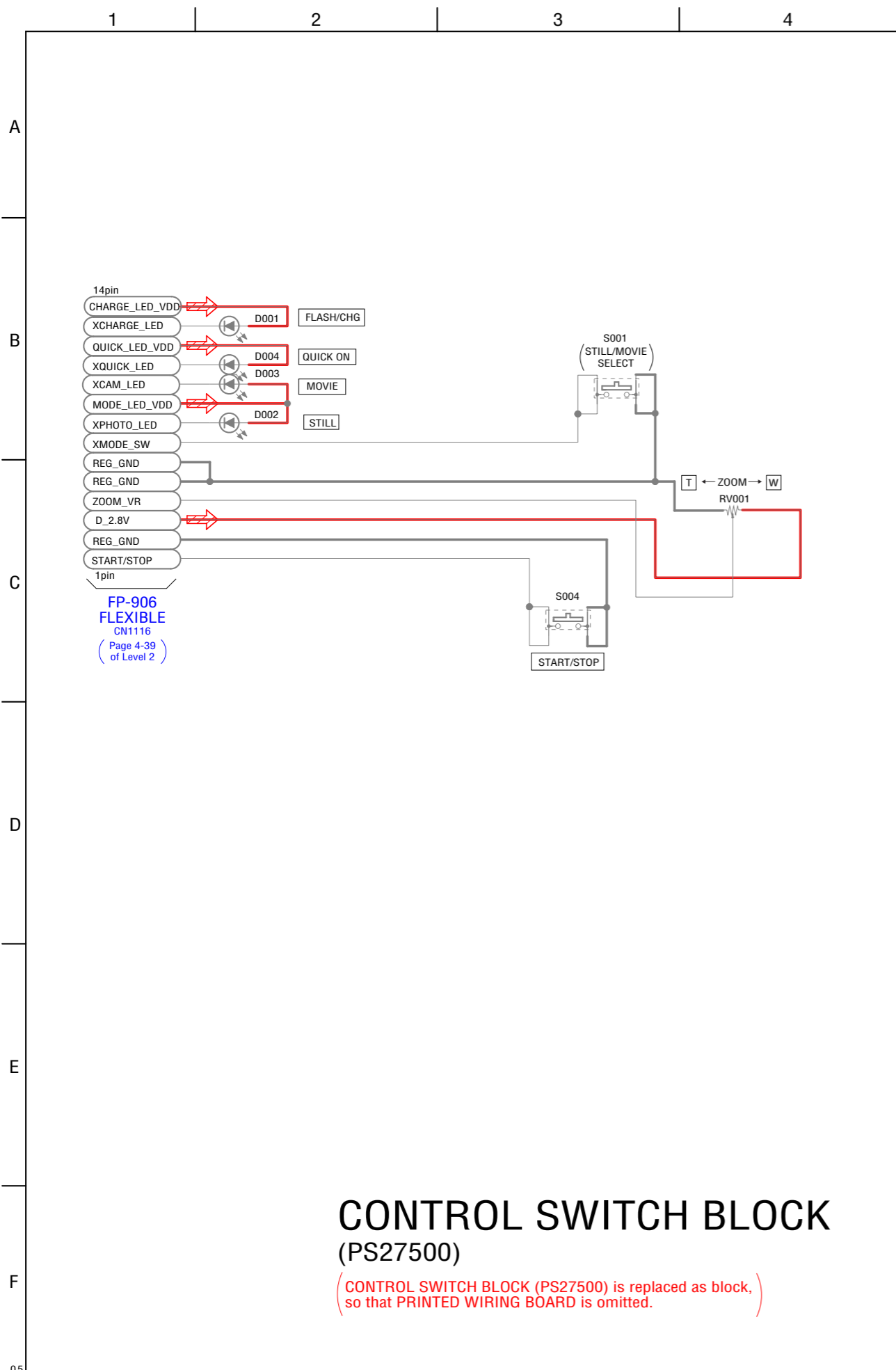

4-3. PRINTED WIRING BOARDS

Link

• FP-902 FLEXIBLE BOARD	• FP-908 FLEXIBLE BOARD
• FP-903 FLEXIBLE BOARD	• FP-909 FLEXIBLE BOARD
• FP-907 FLEXIBLE BOARD	• ST-186 BOARD
• FP-904 FLEXIBLE BOARD	• FP-906 FLEXIBLE BOARD
• MS-396 BOARD	• FP-914 FLEXIBLE BOARD
• FP-905 FLEXIBLE BOARD	• FP-917 FLEXIBLE BOARD







[• COMMON NOTE FOR PRINTED WIRING BOARDS](#)

4-3. PRINTED WIRING BOARDS

4-3. PRINTED WIRING BOARDS

(ENGLISH)

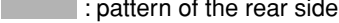
THIS NOTE IS COMMON FOR PRINTED WIRING BOARDS

-  : Uses unleaded solder.
-  : Circuit board
-  : Flexible board
-  : Pattern from the side which enables seeing.
-  : pattern of the rear side
(The other layers' patterns are not indicated)
- Through hole is omitted.
- There are a few cases that the part printed on diagram isn't mounted in this model.
-  : panel designation



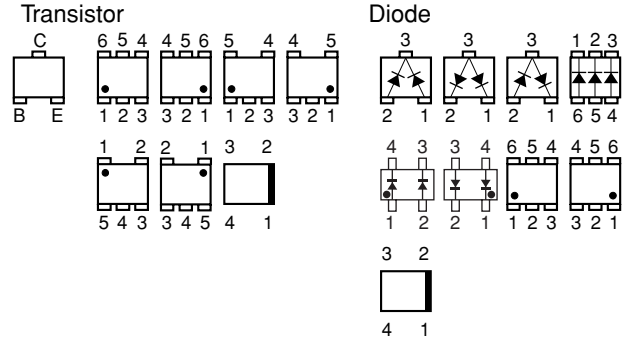



- Chip parts.



(JAPANESE)

プリント図共通ノート

【プリント図ノート】

-  : 無鉛半田を使用しています。
-  : 基板
-  : フレキシブル配線板
-  : 見ている面側のパターン。
-  : 裏側のパターン
(他のパターンについては表示されていません)
- スルーホールは省略。
- プリント図には、本機で使用していない部品が記載されている場合があります。
-  はパネル表示名称。

Printed wiring boards of the CM-096, LD-235, SE-174 and VC-522 boards are not shown.
Pages from 4-41 to 4-43 are not shown.

FP-902 FLEXIBLE BOARD

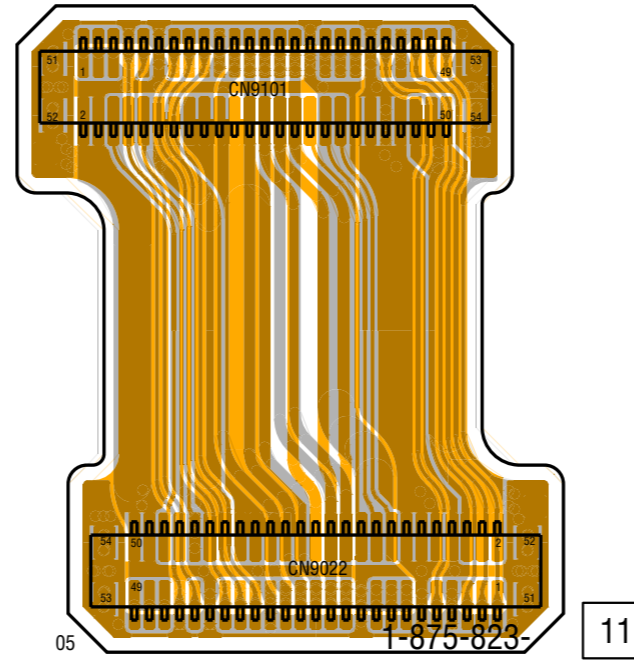

FP-903 FLEXIBLE BOARD

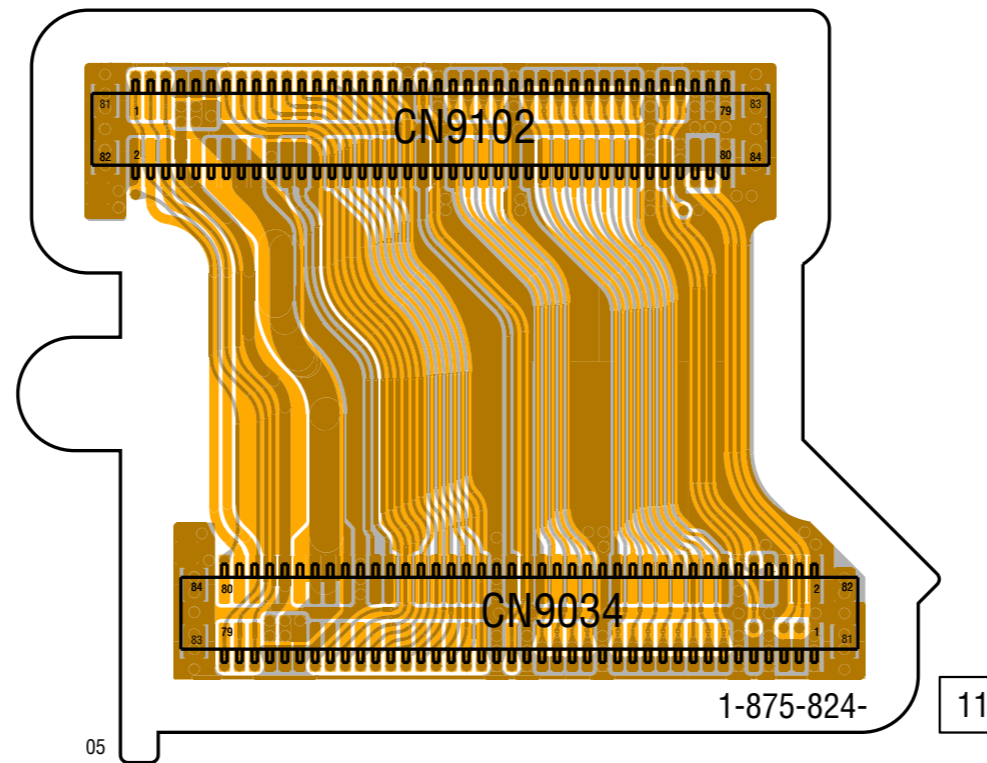

Printed wiring boards of the MD-137 board is not shown.
Page 4-45 is not shown.

 : Uses unleaded solder.

FP-907 FLEXIBLE BOARD

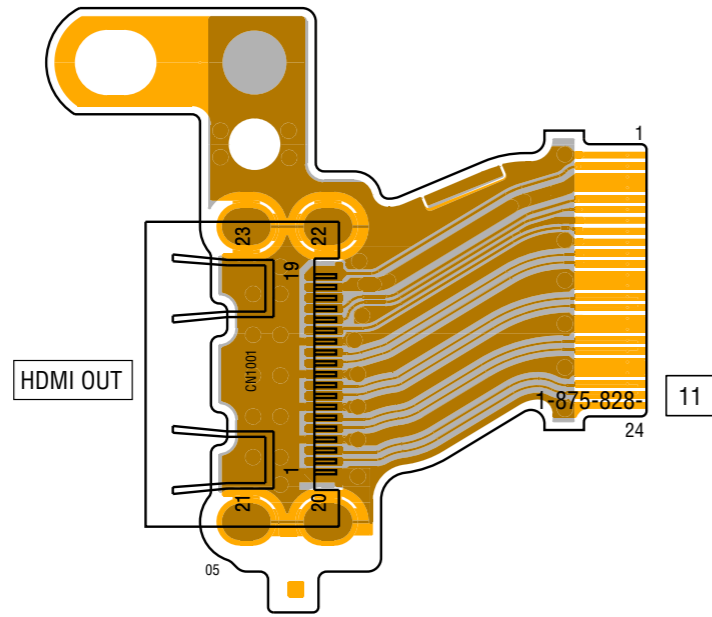

FP-904 FLEXIBLE BOARD

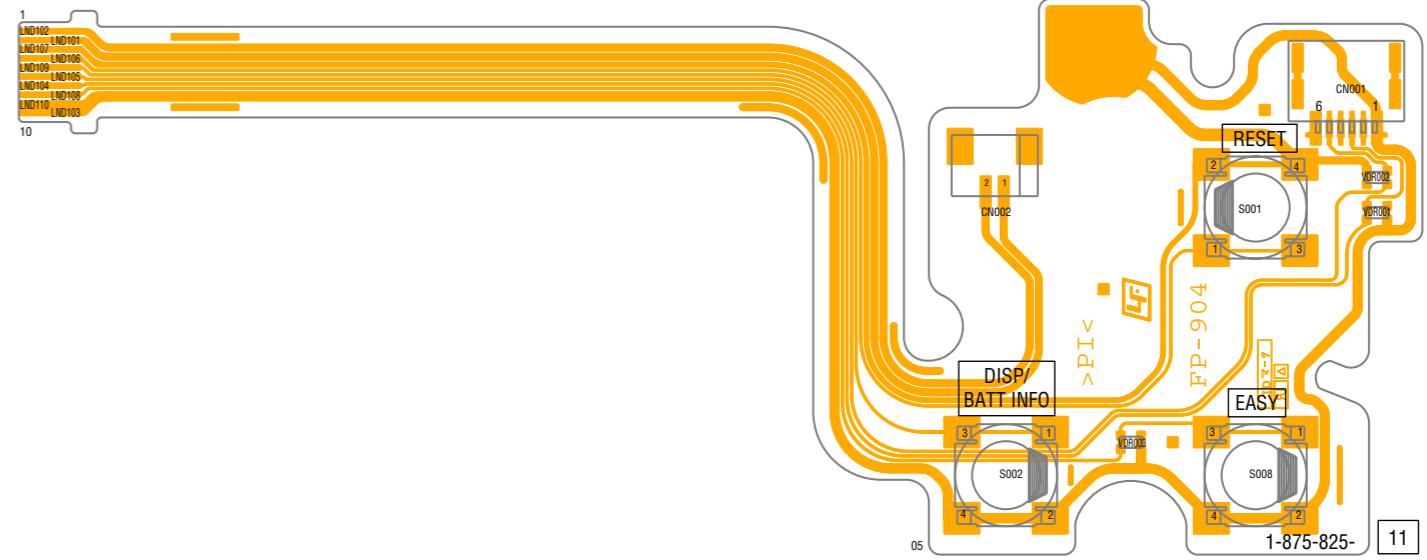

MS-396 BOARD (SIDE A)

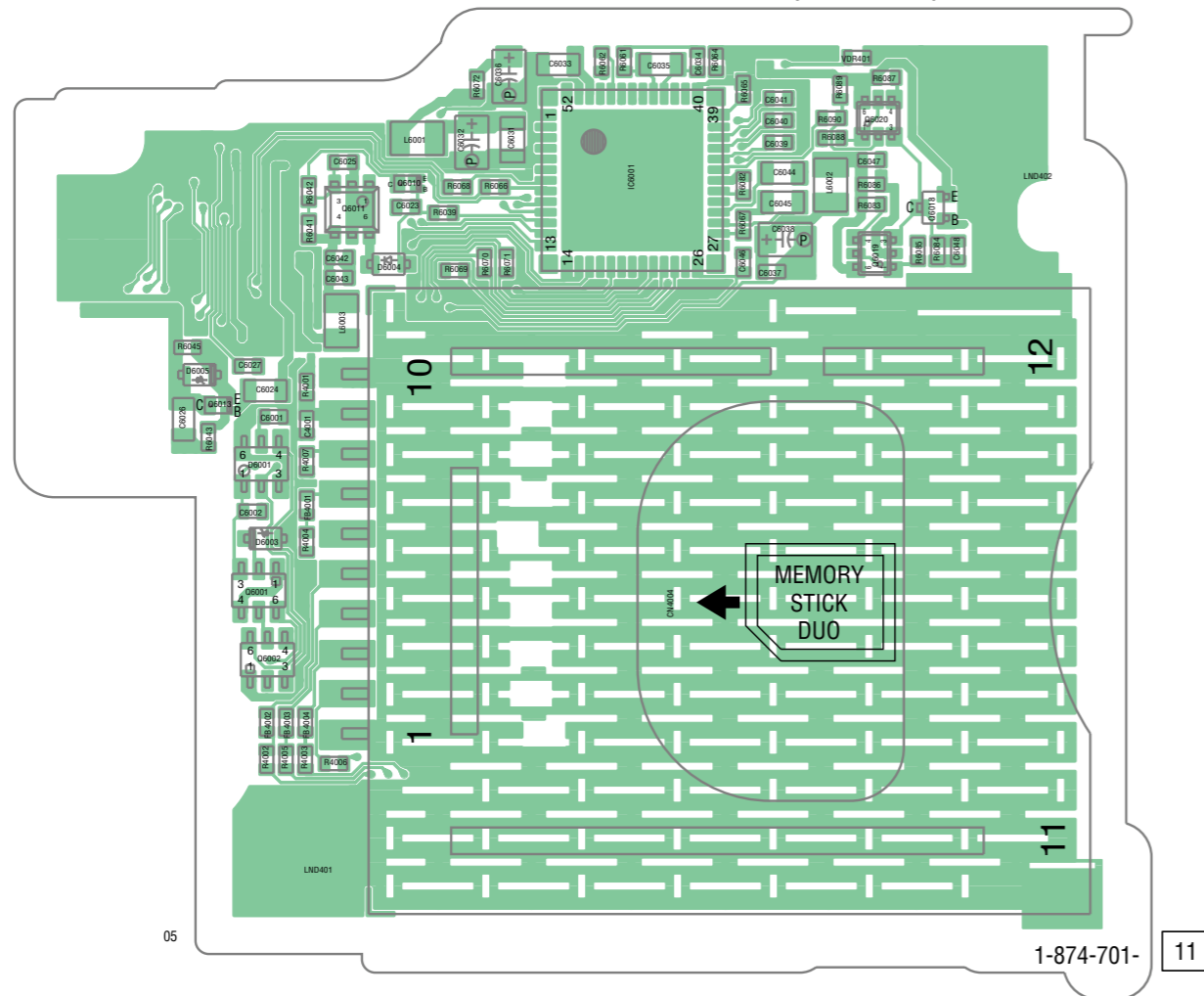

MS-396 BOARD (SIDE B)

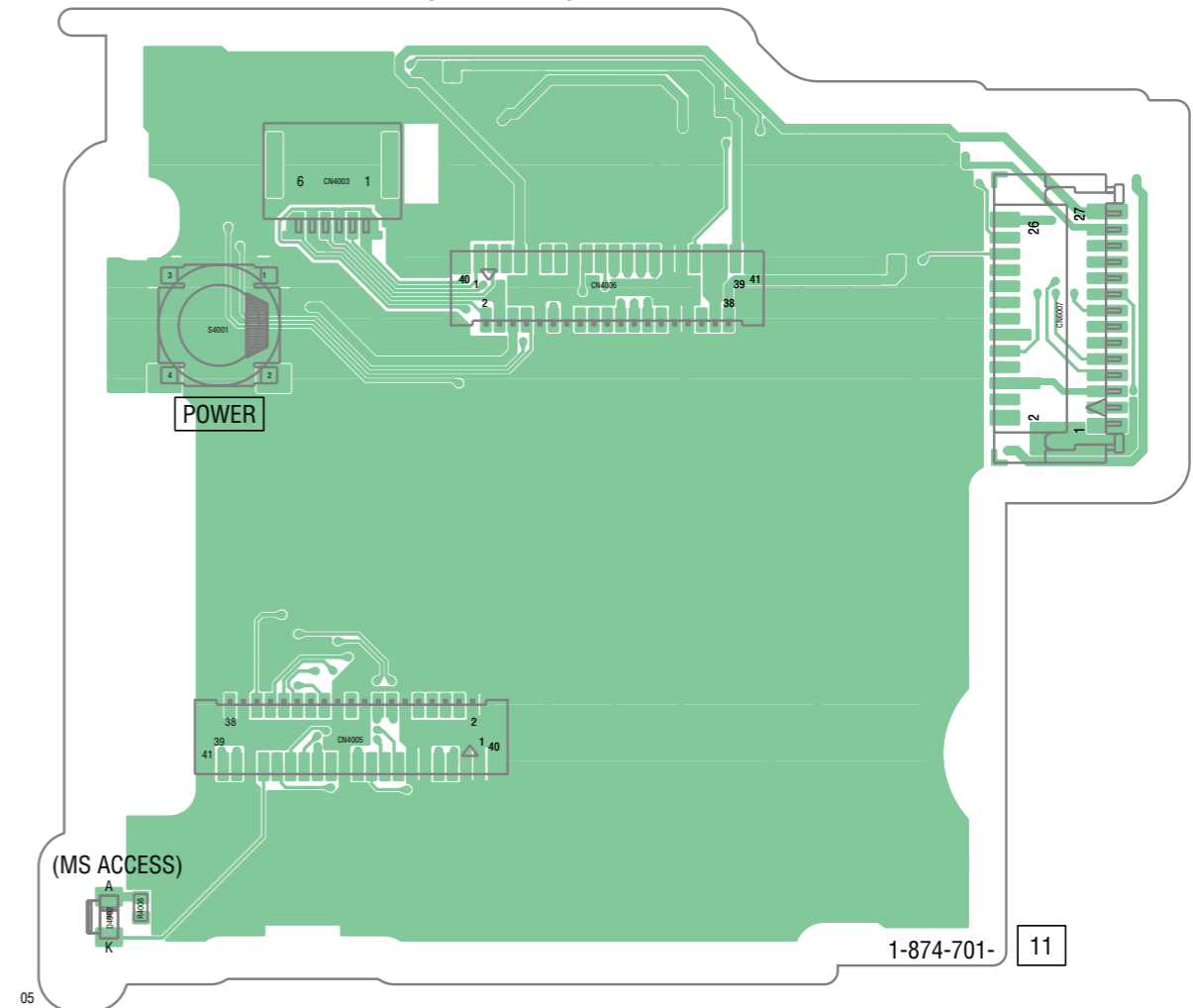

 : Uses unleaded solder.

FP-905 FLEXIBLE BOARD

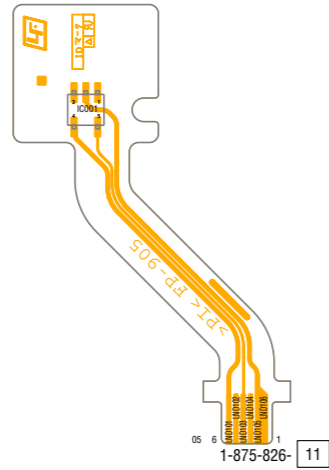

FP-909 FLEXIBLE BOARD

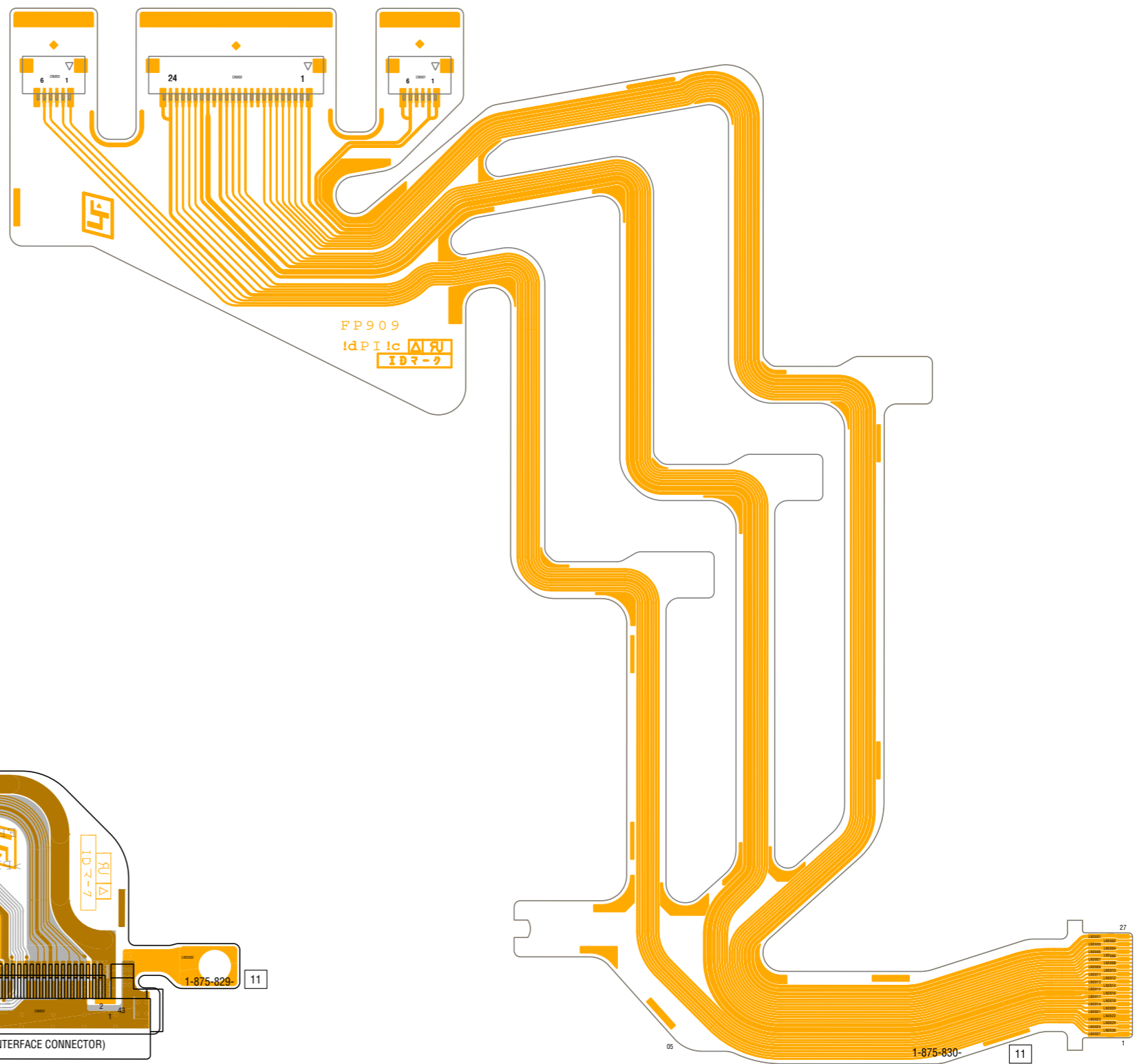

FP-908 FLEXIBLE BOARD

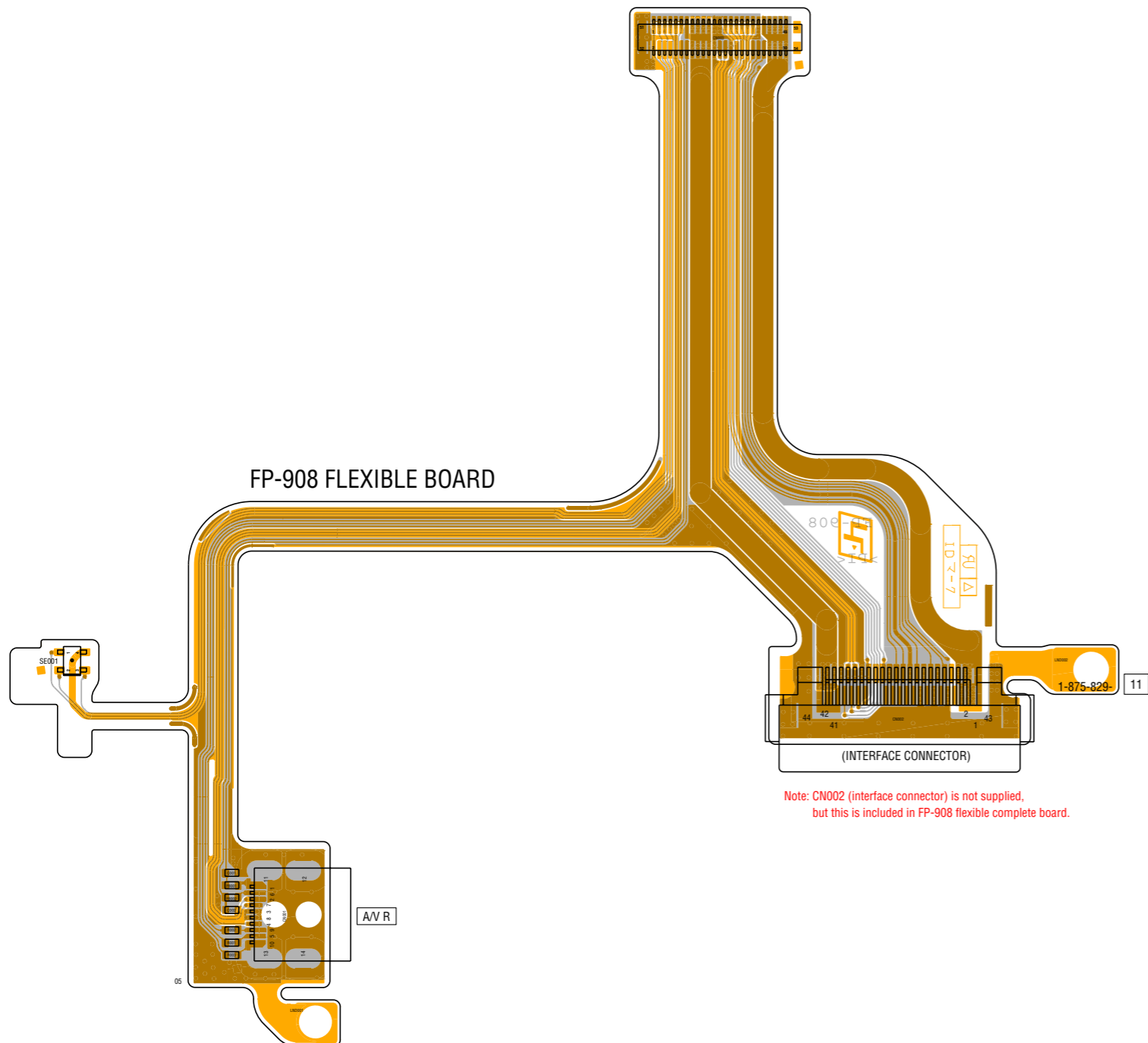

 : Uses unleaded solder.

ST-186 BOARD (SIDE A)

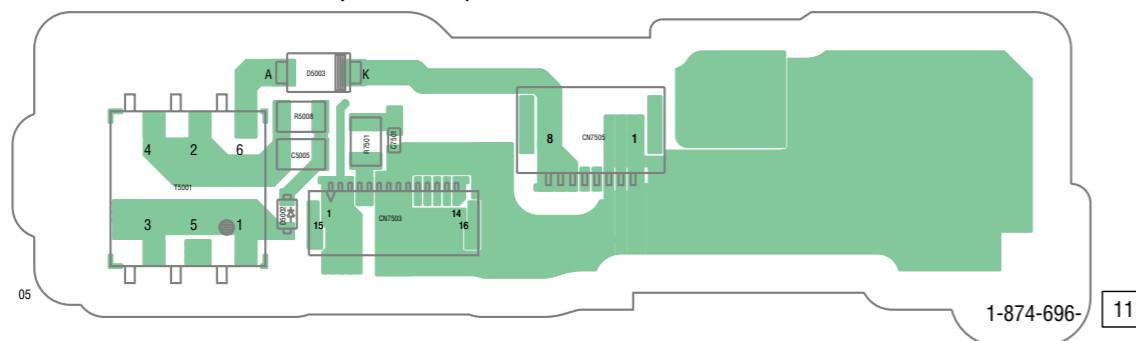

ST-186 BOARD (SIDE B)

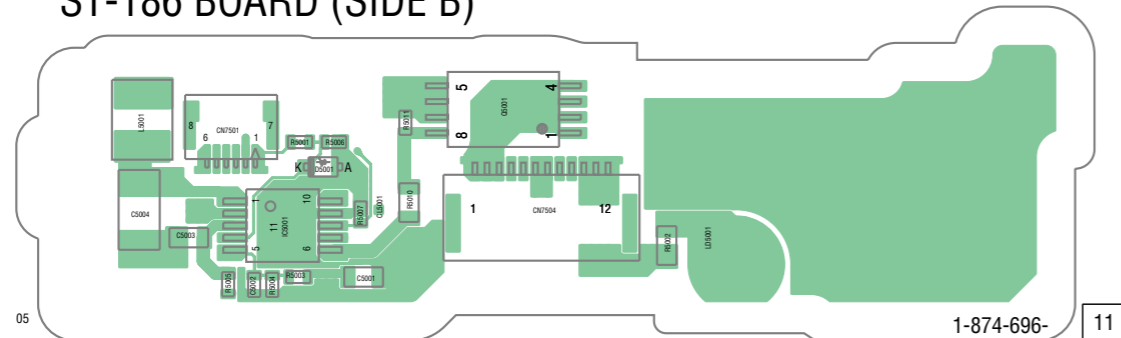

FP-906 FLEXIBLE BOARD

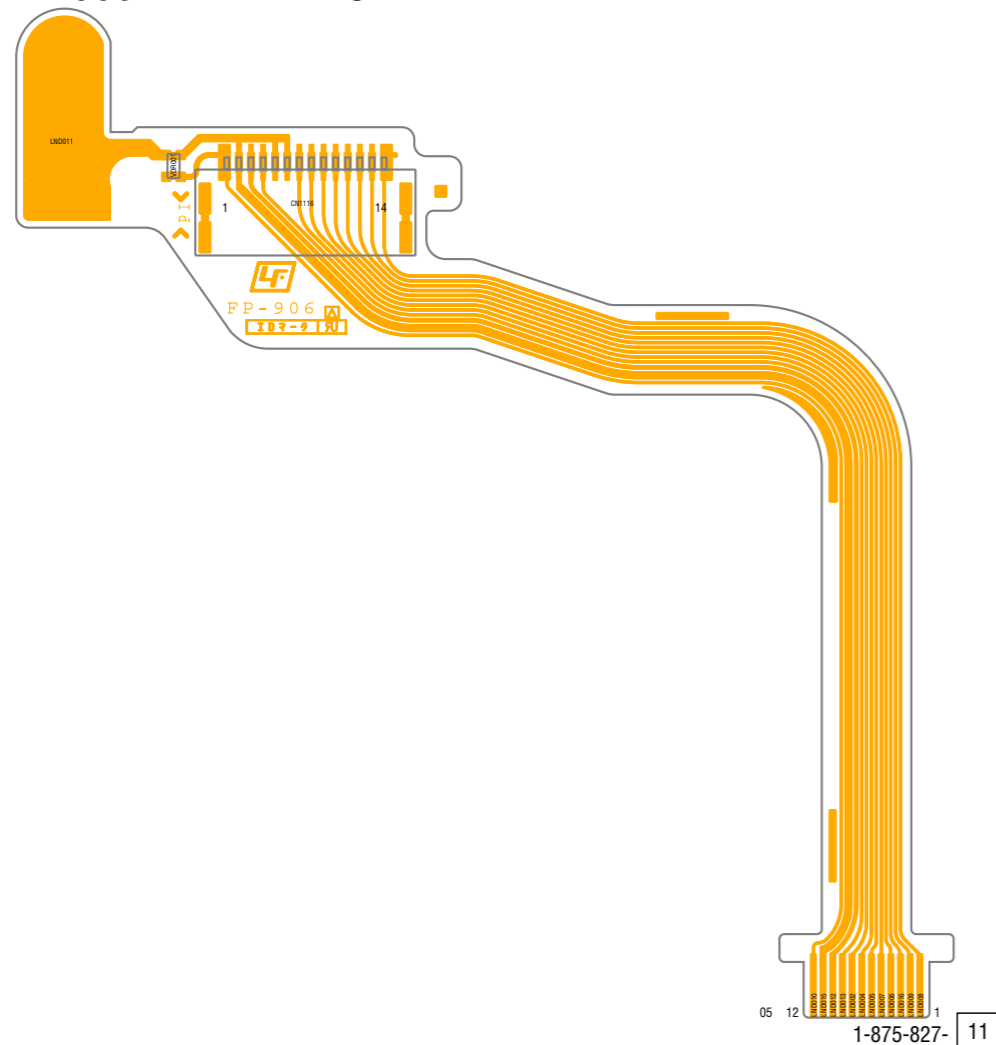

FP-914 FLEXIBLE BOARD

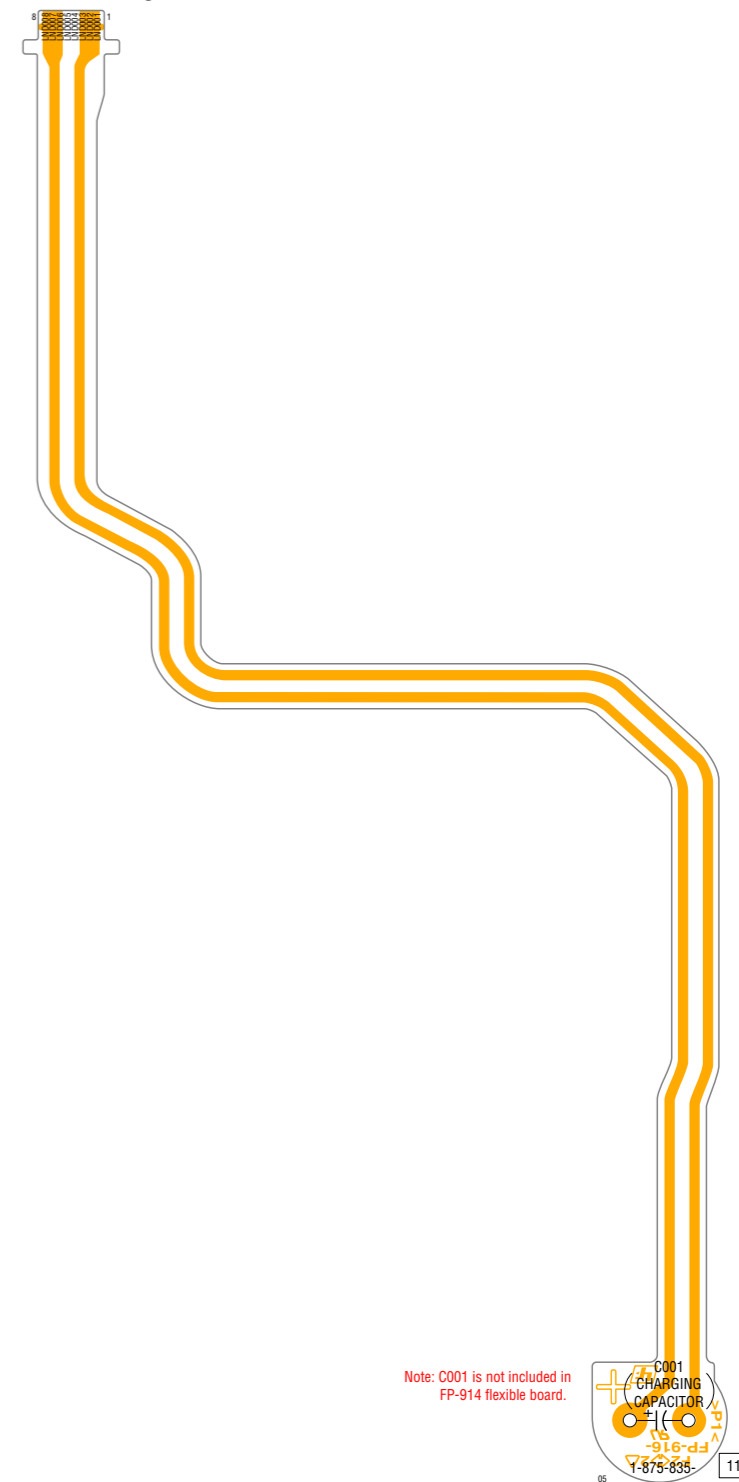

FP-917 FLEXIBLE BOARD

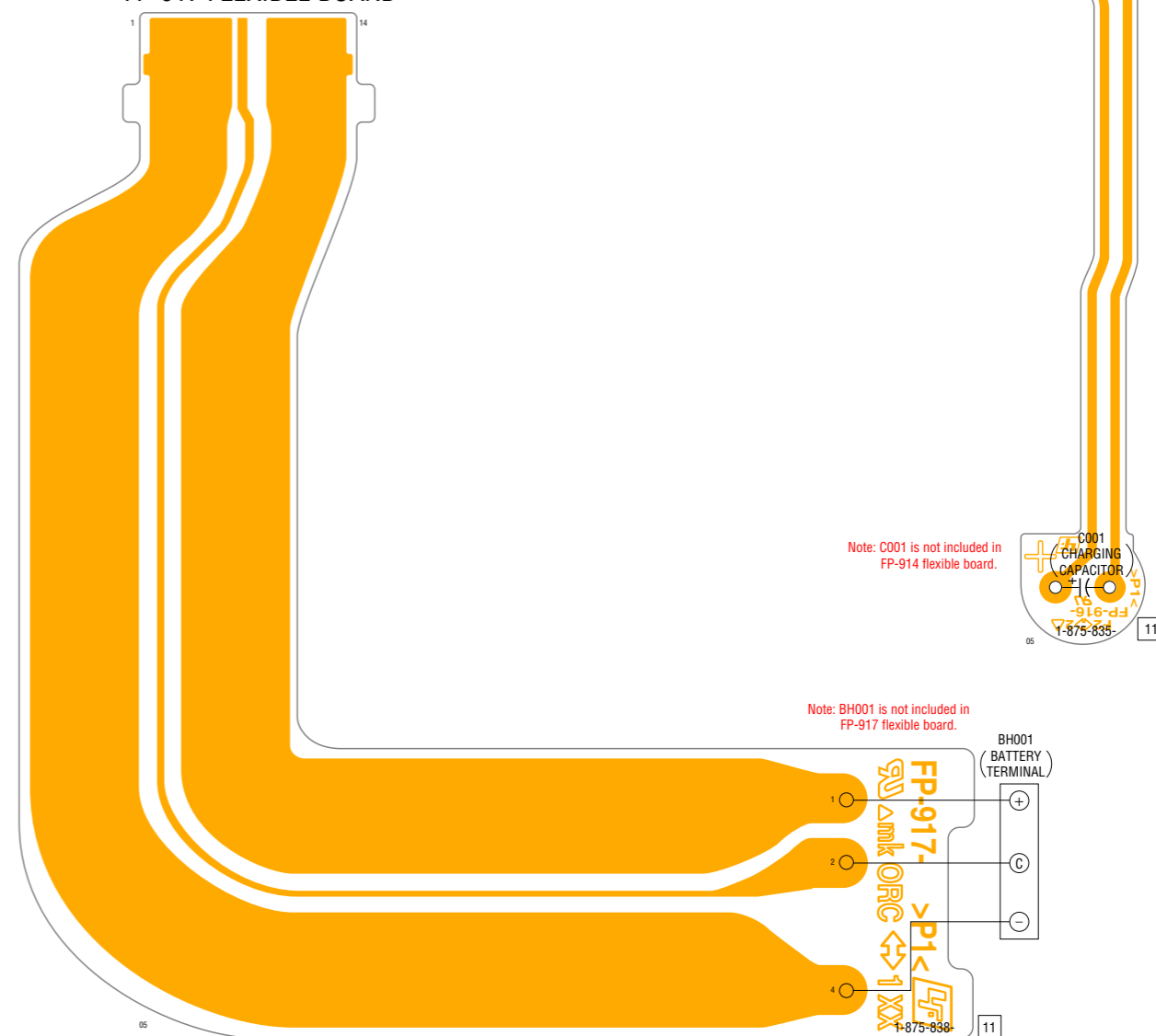

5. REPAIR PARTS LIST

NOTE: Characters **A** to **Z** of the electrical parts list indicate location of exploded views in which the desired part is shown.

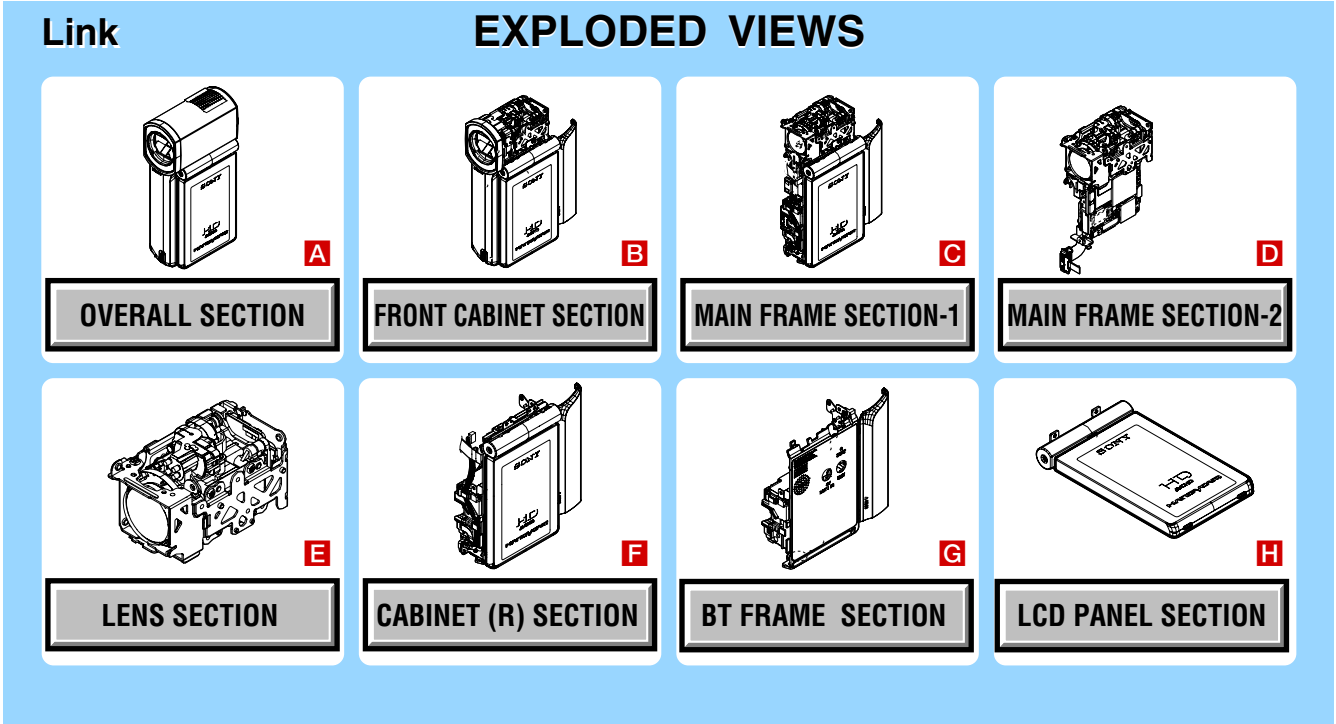

Link	ELECTRICAL PARTS LIST		ACCESSORIES
• FP-902 FLEXIBLE BOARD D	• FP-906 FLEXIBLE BOARD D	• FP-914 FLEXIBLE BOARD F	
• FP-903 FLEXIBLE BOARD D	• FP-907 FLEXIBLE BOARD C	• FP-917 FLEXIBLE BOARD D	
• FP-904 FLEXIBLE BOARD F	• FP-908 FLEXIBLE BOARD F	• MS-396 BOARD B	
• FP-905 FLEXIBLE BOARD C	• FP-909 FLEXIBLE BOARD H	• ST-186 BOARD D	

5. REPAIR PARTS LIST

5. REPAIR PARTS LIST

(ENGLISH)

NOTE:

- -XX, -X mean standardized parts, so they may have some differences from the original one.
- Items marked "*" are not stocked since they are seldom required for routine service. Some delay should be anticipated when ordering these items.
- The mechanical parts with no reference number in the exploded views are not supplied.
- Due to standardization, replacements in the parts list may be different from the parts specified in the diagrams or the components used on the set.
- CAPACITORS:
uF: μ F
- COILS
uH: μ H
- RESISTORS
All resistors are in ohms.
METAL: metal-film resistor
METAL OXIDE: Metal Oxide-film resistor
F: nonflammable
- SEMICONDUCTORS
In each case, u: μ , for example:
uA...: μ A..., uPA..., μ PA...,
uPB..., μ PB..., uPC..., μ PC...,
uPD..., μ PD...

(JAPANESE)

【使用上の注意】

- ここに記載されている部品は、補修用部品であるため、回路図及びセットに付いている部品と異なる場合があります。
- -XX, -Xは標準化部品のため、セットに付いている部品と異なる場合があります。
- *印の部品は常備在庫しておりません。
- コンデンサの単位でuFは μ Fを示します。
- 抵抗の単位 Ω は省略してあります。
金 被：金属被膜抵抗。
サンキン：酸化金属被膜抵抗。
- インダクタの単位でuHは μ Hを示します。
- 半導体の名称でuA..., uPA..., uPB..., uPC..., uPD...等はそれぞれ μ A..., μ PA..., μ PB..., μ PC..., μ PD...を示します。

When indicating parts by reference number, please include the board name.

The components identified by mark Δ or dotted line with mark Δ are critical for safety. Replace only with part number specified.

Les composants identifiés par une marque Δ sont critiques pour la sécurité. Ne les remplacer que par une pièce portant le numéro spécifié.

- Color Indication of Appearance Parts
Example:
(SILVER) : Cabinet's Color
(Silver) : Parts Color

お願い
図面番号で部品を指定するときは基板名又はブロックを併せて指定してください。

Δ 印の部品、または Δ 印付の点線で囲まれた部品は、安全性を維持するために、重要な部品です。従って交換時は、必ず指定の部品を使用してください。

- 外装部品色表示
例：
(SILVER):セットの色を表す。
(Silver) : 部品の色を表す。

- Abbreviation
AR : Argentine model
AUS : Australian model
BR : Brazilian model
CH : Chinese model
CND : Canadian model
EE : East European model
HK : Hong Kong model
J : Japanese model
JE : Tourist model
KR : Korea model
NE : North European model

5. REPAIR PARTS LIST

DISASSEMBLY

HARDWARE LIST

5-1. EXPLODED VIEWS

5-1-1. OVERALL SECTION

ns: not supplied

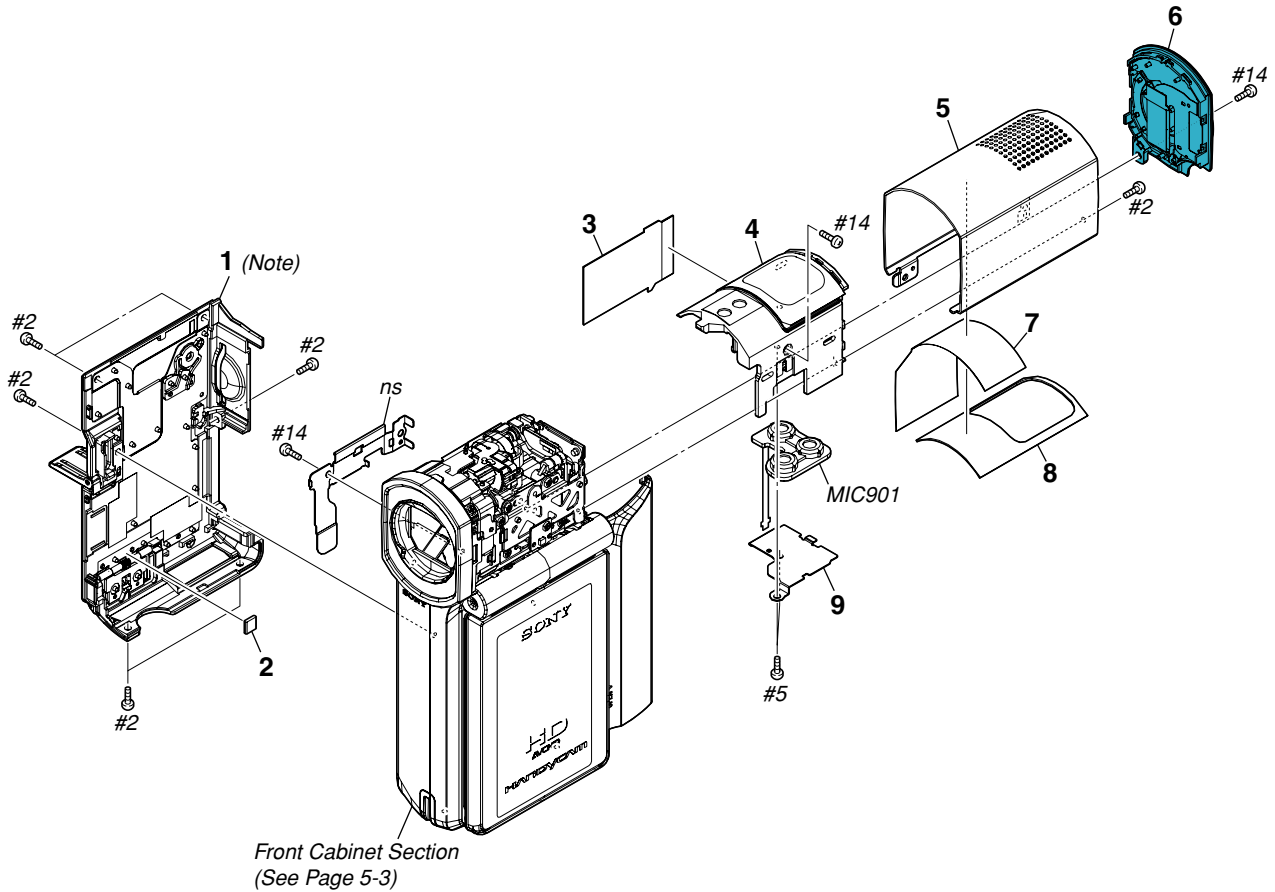

Note: When you exchange CABINET (L), SERVICE be sure to read "1-4. PRECAUTION ON REPLACING THE CABINET (L)" on page 1-3.

Note: サービス用キャビネット (L) 交換時は1-7ページの "1-4. キャビネット (L) 交換時の注意" を必ずお読みください。

Ref. No.	Part No.	Description
1	(Note)	CABINET (L), SERVICE
2	3-870-675-01	GASKET (JN)
* 3	3-300-089-01	SHEET (TL), GUARD
4	X-2189-879-1	CABINET ASSY, INNER (TOP)
5	3-300-102-01	CABINET, TOP
6	1-480-606-11	SWITCH BLOCK, CONTROL (PS27500)
7	3-873-223-01	SHEET (TOP), RADIATION

Ref. No.	Part No.	Description
8	3-300-104-01	SHIELD, MICROPHONE
9	3-300-046-01	FRAME, MICROPHONE
MIC901	1-542-754-11	MICROPHONE UNIT
#2	2-635-562-31	SCREW (M1.7) (Black)
#5	3-080-204-01	SCREW, TAPPING, P2 (Black)
#14	2-599-475-11	SCREW (M1.7) (Silver)

5. REPAIR PARTS LIST

DISASSEMBLY

HARDWARE LIST

5-1-2. FRONT CABINET SECTION

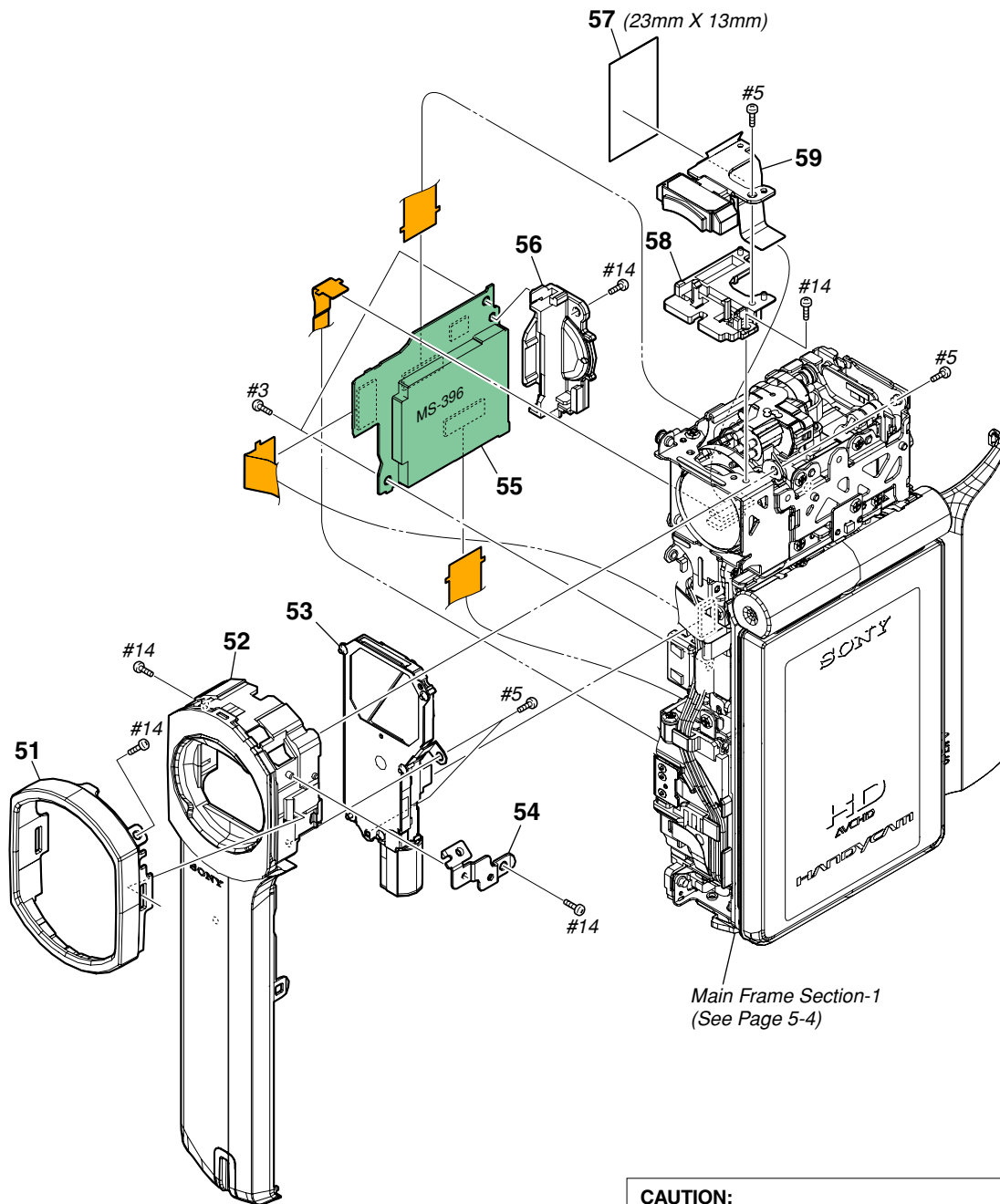

CAUTION:
For the part of 57, cut WOVEN (T0.25), FABRIC NON (3-076-631-01) into the desired length and use it.

CAUTION:
57番は、T0.25ヒメロン(3-076-631-01)を切って使用。

• Refer to page 5-1 for mark △.

Ref. No.	Part No.	Description
51	3-300-076-01	RING, LENS
52	X-2189-888-1	CABINET (F) ASSY
53	A-1494-203-A	LENS BARRIER UNIT
* 54	3-300-077-01	FRAME, RING
55	A-1528-451-A	MS-396 BOARD, COMPLETE
56	3-300-047-01	HOLDER, MS

Ref. No.	Part No.	Description
57	CAUTION	SHEET, MIC
58	3-300-105-01	HOLDER, STROBOSCOPE
△ 59	1-480-610-11	FLASH UNIT (FL27500)
#3	2-660-401-01	SCREW (M1.7), NEW TRU-STAR, P2 (Red)
#5	3-080-204-01	SCREW, TAPPING, P2 (Black)
#14	2-599-475-11	SCREW (M1.7) (Silver)

5. REPAIR PARTS LIST

DISASSEMBLY

HARDWARE LIST

5-1-3. MAIN FRAME SECTION-1

ns: not supplied

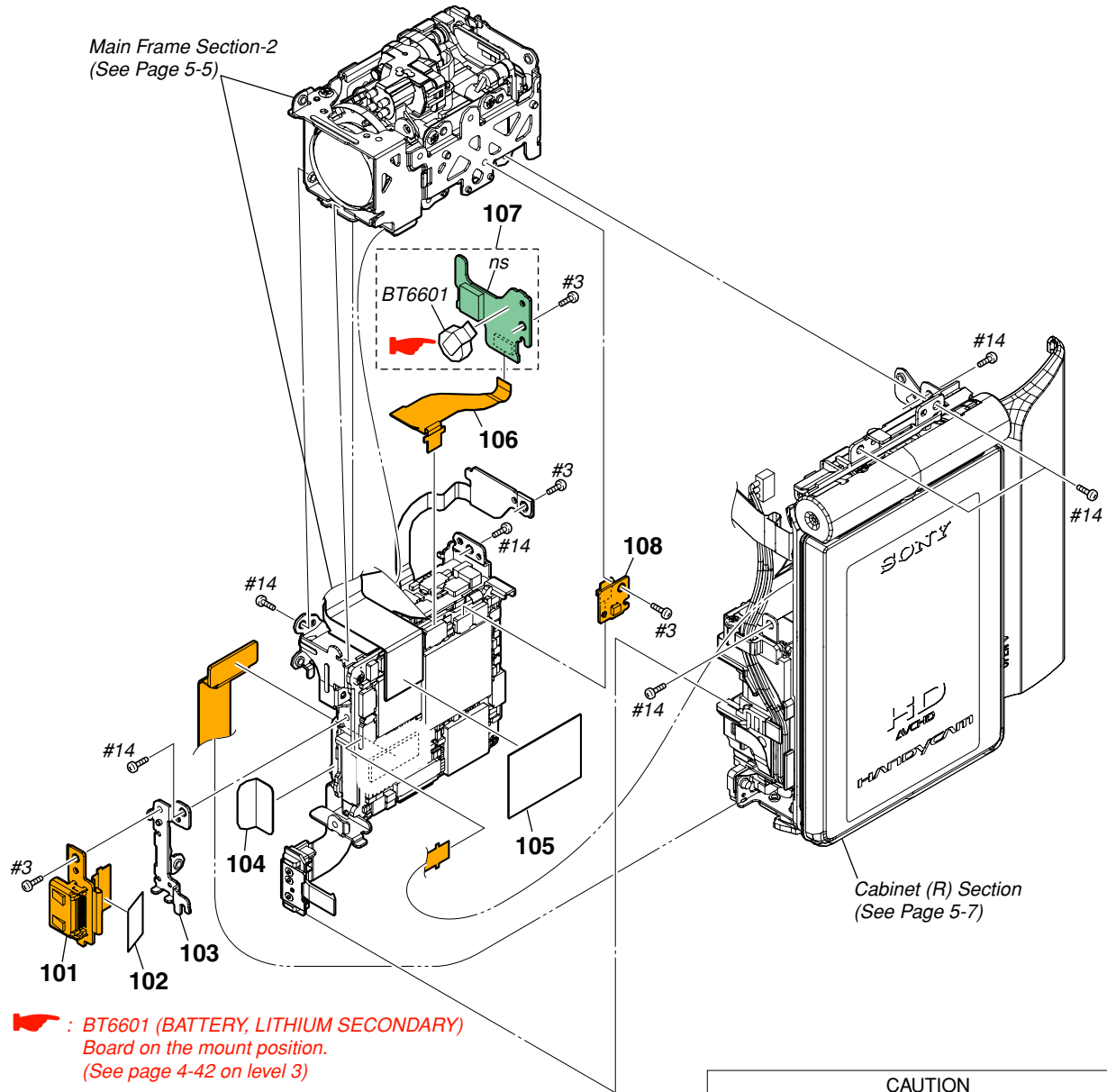

CAUTION
 Danger of explosion if battery is incorrectly replaced.
 Replace only with the same or equivalent type.

注意
 電池の交換は、正しく行わないと破裂する恐れがあります。
 電池を交換する場合には必ず同じ型名の電池
 又は同等品と交換してください。

• Refer to page 5-1 for mark △.

Ref. No.	Part No.	Description
101	A-1528-467-A	FP-907 FLEXIBLE BOARD, COMPLETE
102	3-300-093-01	SHEET, MI RADIATION
103	3-300-086-01	FRAME, JK
104	3-873-225-01	SHEET (BR), GUARD
105	3-300-090-01	SHEET (A), VC
106	1-875-832-11	FP-911 FLEXIBLE BOARD

Ref. No.	Part No.	Description
107	A-1528-449-A	SE-174 BOARD, COMPLETE
108	A-1528-465-A	FP-905 FLEXIBLE BOARD, COMPLETE
△ BT6601	1-528-999-61	BATTERY, LITHIUM SECONDARY
#3	2-660-401-01	SCREW (M1.7), NEW TRU-STAR, P2 (Red)
#14	2-599-475-11	SCREW (M1.7) (Silver)

5. REPAIR PARTS LIST

DISASSEMBLY

HARDWARE LIST

5-1-4. MAIN FRAME SECTION-2

ns: not supplied

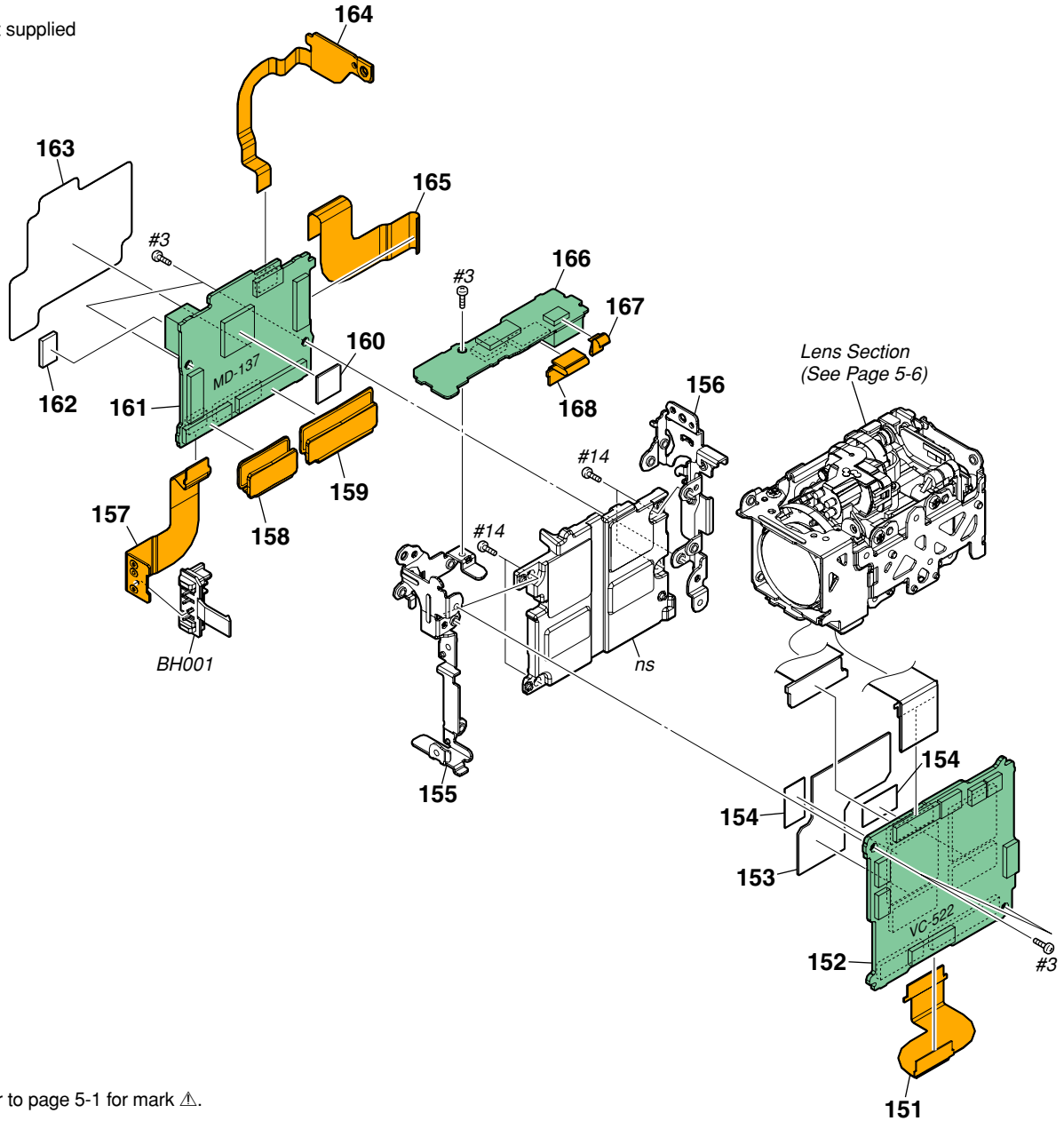

• Refer to page 5-1 for mark △.

Ref. No.	Part No.	Description	Ref. No.	Part No.	Description
151	1-875-834-11	FP-913 FLEXIBLE BOARD	161	A-1530-421-A	MD-137 BOARD, COMPLETE (SERVICE) (TG3E)
152	A-1530-418-A	VC-522 BOARD, COMPLETE (SERVICE) (TG1)	162	3-873-224-01	SPACER, MD
152	A-1530-419-A	VC-522 BOARD, COMPLETE (SERVICE) (TG1E/TG3E)	163	3-300-088-01	LABEL, FUSE REPLACEMENT CAUTION
153	3-300-091-01	SHEET (A), RADIATION	164	A-1528-466-A	FP-906 FLEXIBLE BOARD, COMPLETE
154	3-300-101-01	SHEET, AG COPY	165	1-875-837-11	FP-916 FLEXIBLE BOARD
* 155	3-300-081-01	FRAME (FRONT), MAIN	166	A-1528-450-A	ST-186 BOARD, COMPLETE
* 156	3-300-083-01	FRAME (REAR), MAIN	167	1-875-833-11	FP-912 FLEXIBLE BOARD
157	1-875-838-11	FP-917 FLEXIBLE BOARD	168	1-875-836-11	FP-915 FLEXIBLE BOARD
158	A-1528-452-A	FP-902 FLEXIBLE BOARD, COMPLETE	△ BH001	1-780-597-11	TERMINAL BOARD, BATTERY
159	A-1528-464-A	FP-903 FLEXIBLE BOARD, COMPLETE	#3	2-660-401-01	SCREW (M1.7), NEW TRU-STAR, P2 (Red)
160	3-300-092-01	SHEET (N), RADIATION	#14	2-599-475-11	SCREW (M1.7) (Silver)
161	A-1530-420-A	MD-137 BOARD, COMPLETE (SERVICE) (TG1/TG1E)			

Ver. 1.2 2008.09

The changed portions from Ver. 1.1 are shown in blue.

5. REPAIR PARTS LIST

HARDWARE LIST

5-1-5. LENS SECTION

ns: not supplied

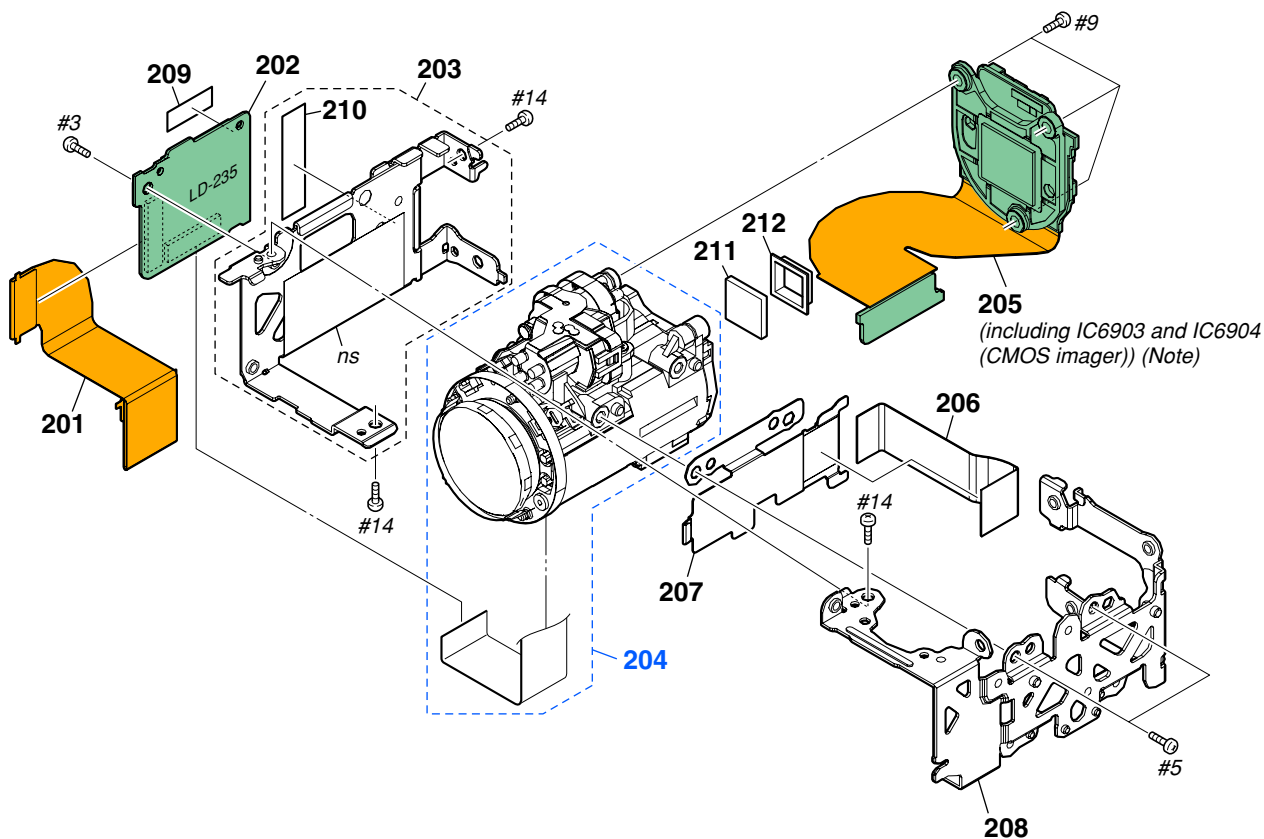

Note: Be sure to read "Precautions for Replacement of Imager" on page 4-2 when changing the imager.

Note: イメージャの交換時は4-3ページの“イメージャ交換時の注意”を必ずお読みください。

Ref. No.	Part No.	Description
201	1-875-831-11	FP-910 FLEXIBLE BOARD
202	A-1528-468-A	LD-235 BOARD, COMPLETE (TG1)
202	A-1543-261-A	LD-235 BOARD, COMPLETE (TG1E/TG3E)
203	X-2189-889-1	HEAT SINK ASSY, CM
204	1-788-710-11	OPTICAL UNIT (CH001)
205	A-1528-469-A	CM-096 BOARD, COMPLETE (including IC6903 and IC6904 (CMOS imager)) (Note)
206	3-300-080-01	SHEET, CM RADIATION
207	3-300-079-01	HEAT SINK (R), CM
208	3-300-078-01	FRAME, LENS

Ref. No.	Part No.	Description
* 209	3-878-478-01	SHEET, URU
* 210	2-887-640-01	SHEET (BL), PROTECTION
211	1-788-737-11	OPTICAL FILTER BLOCK (OFB-05-06)
212	3-279-478-01	RUBBER (CH001), SEAL
#3	2-660-401-01	SCREW (M1.7), NEW TRU-STAR, P2 (Red)
#5	3-080-204-01	SCREW, TAPPING, P2 (Black)
#9	3-078-890-21	SCREW, TAPPING (Silver)
#14	2-599-475-11	SCREW (M1.7) (Silver)

5. REPAIR PARTS LIST

DISASSEMBLY

HARDWARE LIST

5-1-6. CABINET (R) SECTION

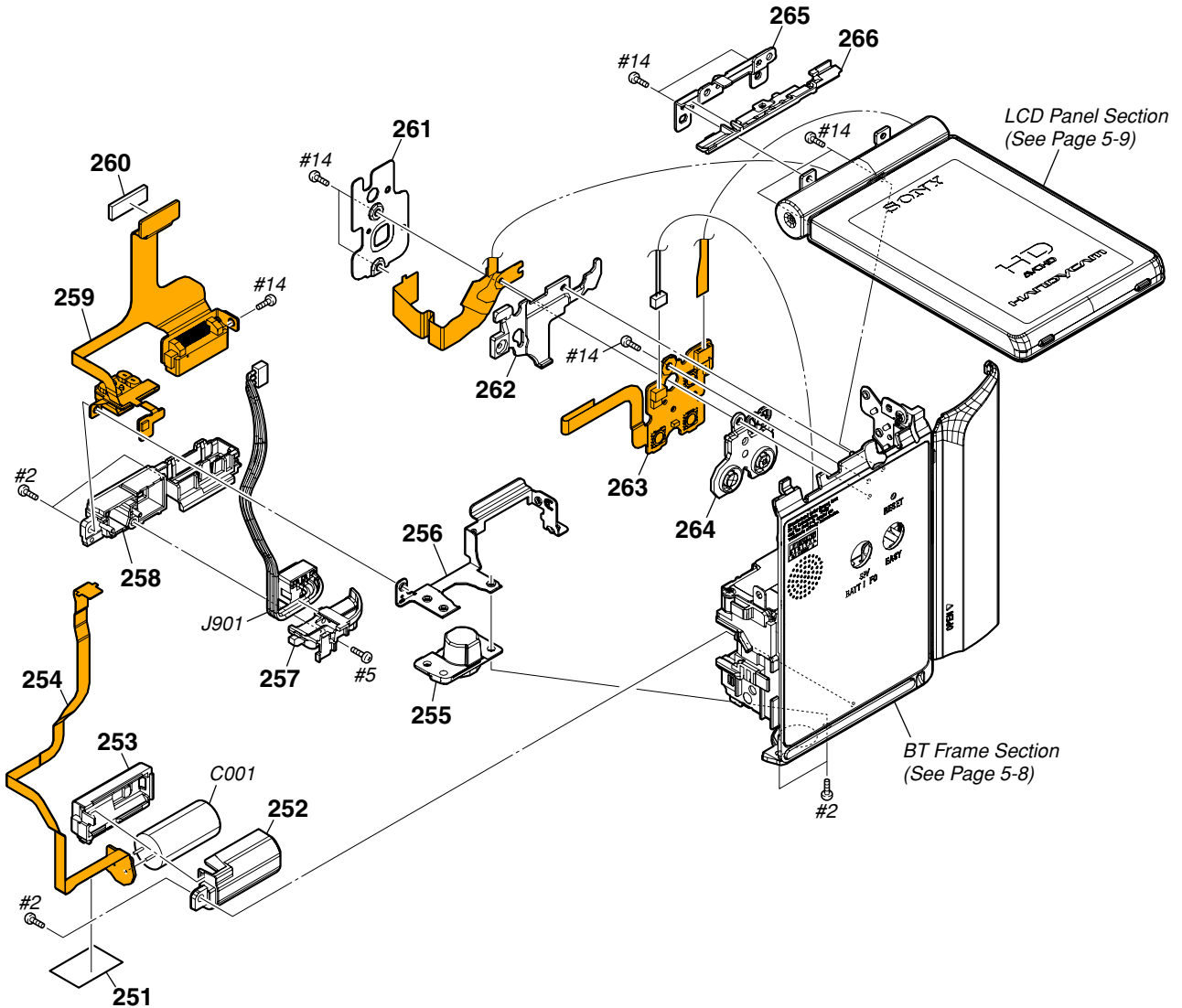

• Refer to page 5-1 for mark \triangle .

Ref. No.	Part No.	Description
* 251	3-300-053-01	SHEET, CAPACITOR
252	3-300-051-01	HOLDER, CAPACITOR
253	3-300-052-01	COVER, CAPACITOR
254	1-875-835-11	FP-914 FLEXIBLE BOARD
255	3-300-050-01	WASHER, TRIPOD
* 256	3-300-055-01	FRAME, BOTTOM
* 257	3-300-054-01	RETAINER, TERMINAL
258	3-300-049-01	HOLDER, JK
259	A-1528-473-A	FP-908 FLEXIBLE BOARD, COMPLETE
260	3-300-099-01	SPACER, CR
* 261	3-300-057-01	RETAINER, CF BUTTON

Ref. No.	Part No.	Description
* 262	3-300-059-01	BLIND, VC
263	A-1528-472-A	FP-904 FLEXIBLE BOARD, COMPLETE
264	X-2189-883-1	BUTTON ASSY, CF
* 265	3-300-060-01	STABILIZER
* 266	3-300-061-01	BLIND, HINGE
\triangle C001	1-114-722-11	ELECT 37uF 330V
\triangle J901	1-821-769-11	JACK, DC (DC IN)
#2	2-635-562-31	SCREW (M1.7) (Black)
#5	3-080-204-01	SCREW, TAPPING, P2 (Black)
#14	2-599-475-11	SCREW (M1.7) (Silver)

5. REPAIR PARTS LIST

HARDWARE LIST

5-1-7. BT FRAME SECTION

ns: not supplied

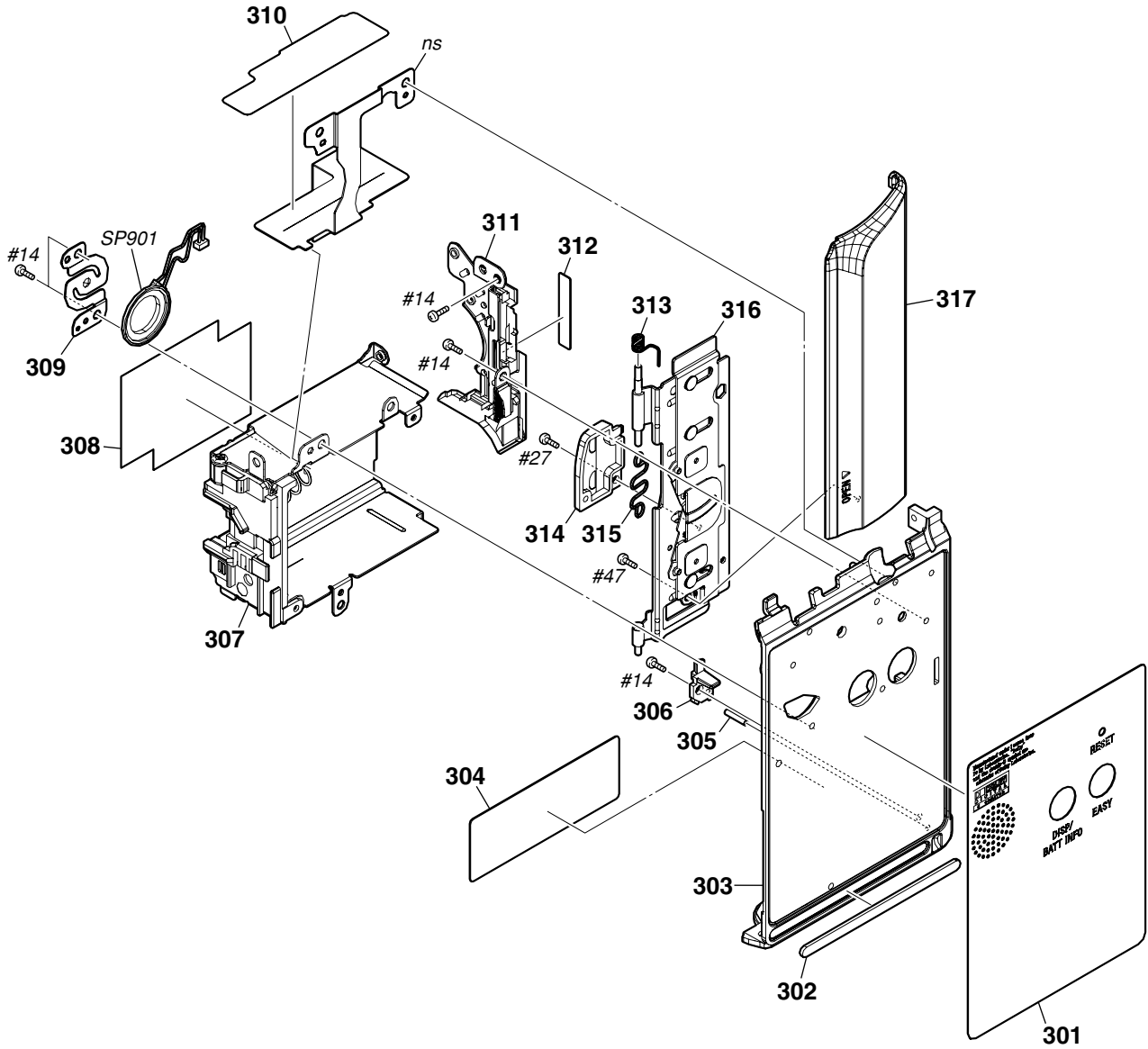

Ref. No.	Part No.	Description
301	3-300-107-01	PLATE (R), ORNAMENTAL (TG1/TG1E)
301	3-300-107-11	PLATE (R), ORNAMENTAL (TG3E)
302	3-300-008-01	CUSHION, PANEL
303	3-300-005-01	CABINET (R)
304	3-300-007-01	SHEET, BT SLIDER
305	3-300-010-01	SHAFT, STRAP
306	3-300-006-01	RETAINER (LOWER), BT LID
307	X-2189-882-1	FRAME ASSY, BT
308	3-873-201-01	SHEET (BT), RADIATION
* 309	3-300-056-01	RETAINER, SPEAKER
310	3-300-058-01	SHEET, BT PROTECTION

Ref. No.	Part No.	Description
311	X-2318-015-1	BT LOCK HOOK ASSY
312	3-300-106-01	COVER, CPC
313	3-300-009-01	SPRING, BT LID
314	3-300-000-01	COVER, BT LINK
315	3-299-999-01	SPRING, BT LINK
316	X-2189-881-1	PLATE ASSY, BT SLIDE
317	3-300-103-01	LID, BT
SP901	1-826-837-11	SPEAKER (1.3CM)
#14	2-599-475-11	SCREW (M1.7) (Silver)
#27	2-662-396-11	SCREW (M1.4), NEW, TRUSTAR, P2 (Black)
#47	2-665-774-01	SCREW (Silver)

5. REPAIR PARTS LIST

HARDWARE LIST

5-1-8. LCD PANEL SECTION

ns: not supplied

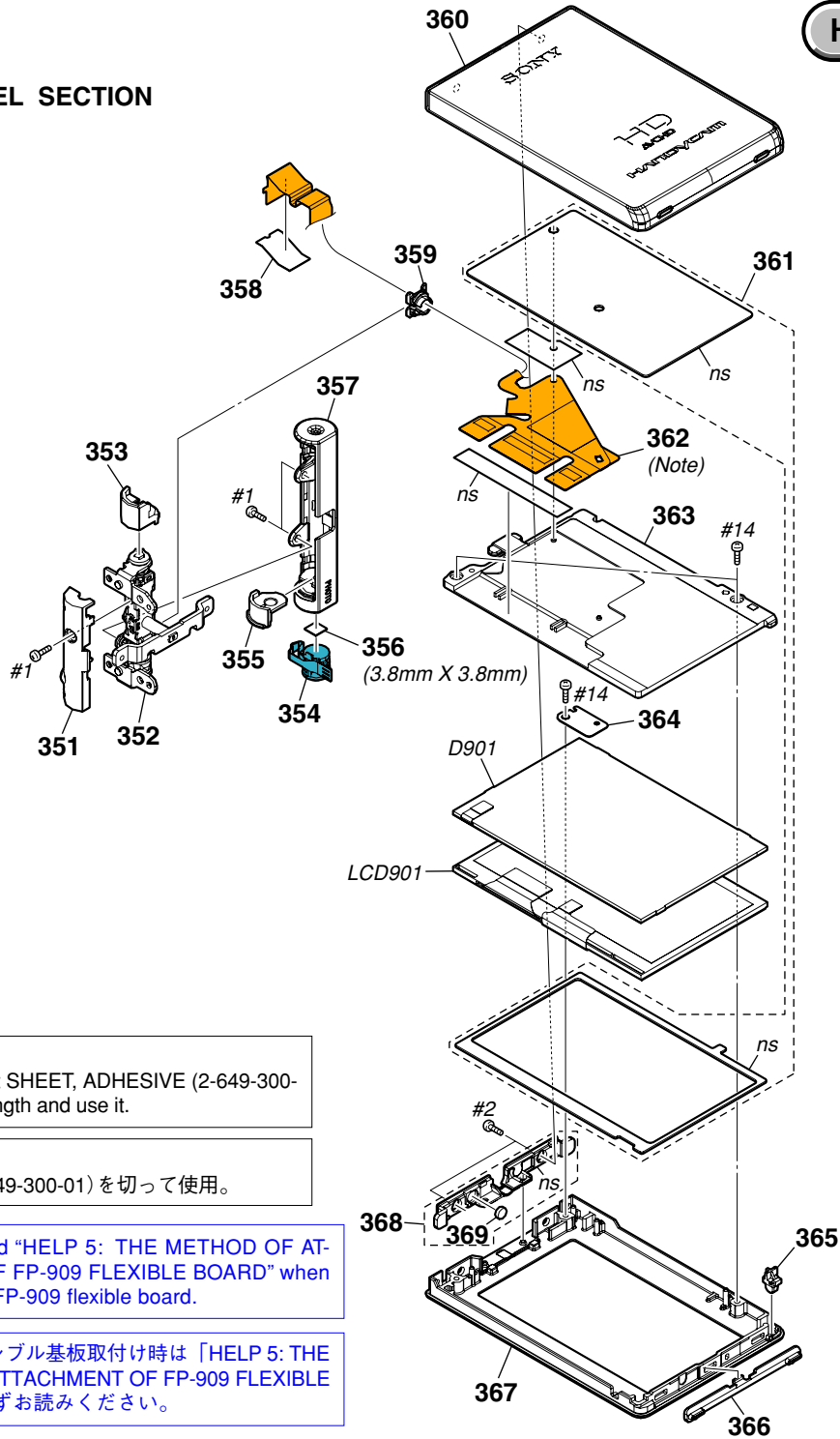

CAUTION:
For the part of 356, cut SHEET, ADHESIVE (2-649-300-01) into the desired length and use it.

CAUTION:
356番は、接着紙(2-649-300-01)を切って使用。

Note: Be sure to read "HELP 5: THE METHOD OF ATTACHMENT OF FP-909 FLEXIBLE BOARD" when you install the FP-909 flexible board.

Note: FP-909フレキシブル基板取付け時は「HELP 5: THE METHOD OF ATTACHMENT OF FP-909 FLEXIBLE BOARD」を必ずお読みください。

Ref. No.	Part No.	Description
351	3-300-066-01	COVER (REAR), HINGE
352	X-2189-884-1	HINGE ASSY
353	3-300-069-01	COVER, F HINGE
354	1-480-607-11	SWITCH BLOCK, CONTROL (PH27500)
355	3-300-068-01	COVER, PH BUTTON
356	CAUTION	SHEET, PH ADHESIVE
357	3-300-065-01	COVER (FRONT), HINGE
358	3-300-100-01	SHEET, JN COPY
359	3-300-070-01	CLAMP, HINGE
360	3-300-062-01	CABINET (C), P
361	X-2318-318-1	CUSHION ASSY, TP
362	A-1528-470-A	FP-909 FLEXIBLE BOARD, COMPLETE (Note)
363	X-2189-886-1	SPACER ASSY, PANEL

Ref. No.	Part No.	Description
364	3-300-064-01	RETAINER, LCD
365	3-300-071-01	GUIDE (CHIBITOKU), PANEL
366	3-300-072-01	HOOK, PANEL
367	X-2189-885-1	CABINET (M) ASSY, P
368	X-2189-887-1	BAND ASSY, PANEL COVER
369	1-471-278-11	MAGNET
D901	1-480-681-11	BLOCK, LIGHT GUIDE PLATE (2.7) (BACKLIGHT)
LCD901	A-1438-502-A	TP BLOCK ASSY (27ESTMG08)
#1	2-635-562-11	SCREW (M1.7) (Black)
#2	2-635-562-31	SCREW (M1.7) (Black)
#14	2-599-475-11	SCREW (M1.7) (Silver)

Electrical parts list of the CM-096 board is not shown.
Page 5-10 is not shown.

5-2. ELECTRICAL PARTS LIST

Ref. No.	Part No.	Description
	A-1528-452-A	FP-902 FLEXIBLE BOARD, COMPLETE ***** < CONNECTOR >
* CN9022	1-820-778-11	CONNECTOR, BOARD TO BOARD
* CN9101	1-820-778-11	CONNECTOR, BOARD TO BOARD
	A-1528-464-A	FP-903 FLEXIBLE BOARD, COMPLETE ***** < CONNECTOR >
* CN9034	1-821-894-11	CONNECTOR, BOARD TO BOARD 80P
* CN9102	1-821-894-11	CONNECTOR, BOARD TO BOARD 80P
	A-1528-472-A	FP-904 FLEXIBLE BOARD, COMPLETE ***** < CONNECTOR >
* CN001	1-816-654-51	FFC/FPC CONNECTOR (LIF) 6P
CN002	1-794-375-21	PIN, CONNECTOR 2P
		< SWITCH >
S001	1-771-138-21	SWITCH, KEY BOARD (RESET)
S002	1-771-138-21	SWITCH, KEY BOARD (DISP/BATT INFO)
S008	1-771-138-21	SWITCH, KEY BOARD (EASY)
	A-1528-465-A	FP-905 FLEXIBLE BOARD, COMPLETE ***** < IC >
IC001	6-705-011-01	IC AN48830B-NL
	A-1528-466-A	FP-906 FLEXIBLE BOARD, COMPLETE ***** < CONNECTOR >
* CN1116	1-816-645-51	FFC/FPC CONNECTOR (LIF) 14P
	A-1528-467-A	FP-907 FLEXIBLE BOARD, COMPLETE ***** < CONNECTOR >
CN1001	1-821-166-21	CONNECTOR, HDMI (HDMI OUT)
	A-1528-473-A	FP-908 FLEXIBLE BOARD, COMPLETE ***** (CN002 (interface connector) is not supplied, but this is included in FP-908 flexible complete board.) < CAPACITOR >
C001	1-164-933-11	CERAMIC CHIP 220PF 10% 50V
C002	1-164-933-11	CERAMIC CHIP 220PF 10% 50V

Ref. No.	Part No.	Description
		< CONNECTOR >
CN001	1-815-794-13	CONNECTOR (MULTIPLE) (A/V R)
△ CN002	(Not supplied)	CONNECTOR, MULTIPLE (SOCKET) (INTERFACE CONNECTOR) (CN002 is supplied including in FP-908 flexible complete board.)
* CN003	1-820-778-11	CONNECTOR, BOARD TO BOARD
		< FERRITE BEAD >
FB001	1-400-927-31	BEAD, FERRITE (1005)
FB002	1-400-927-31	BEAD, FERRITE (1005)
		< RESISTOR >
R001	1-218-990-81	SHORT CHIP 0
R002	1-218-990-81	SHORT CHIP 0
R003	1-218-990-81	SHORT CHIP 0
		< SENSOR >
* SE001	1-480-627-11	SENSOR, MAGNETIC
	A-1528-470-A	FP-909 FLEXIBLE BOARD, COMPLETE ***** < CONNECTOR >
* CN001	1-818-619-71	CONNECTOR, FFC/FPC (ZIF) 6P
* CN002	1-821-835-71	CONNECTOR, FFC/FPC (ZIF) 24P
* CN003	1-818-619-71	CONNECTOR, FFC/FPC (ZIF) 6P
	1-875-835-11	FP-914 FLEXIBLE BOARD ***** (C001 is not included in FP-914 flexible board.) < CAPACITOR >
△ C001	1-114-722-11	ELECT 37uF 330V
	1-875-838-11	FP-917 FLEXIBLE BOARD ***** (BH001 is not included in FP-917 flexible board.) < BATTERY TERMINAL >
△ BH001	1-780-597-11	TERMINAL BOARD, BATTERY

Electrical parts list of the LD-235 and MD-137 boards are not shown.
Pages 5-12 to 5-16 are not shown.

• Refer to page 5-1 for mark △.

Ref. No.	Part No.	Description
	A-1528-451-A	MS-396 BOARD, COMPLETE *****
		< CAPACITOR >
C4001	1-125-777-11	CERAMIC CHIP 0.1uF 10% 10V
C6001	1-100-581-81	CERAMIC CHIP 0.0047uF 10% 50V
C6002	1-100-581-81	CERAMIC CHIP 0.0047uF 10% 50V
C6024	1-165-908-11	CERAMIC CHIP 1uF 10% 10V
C6025	1-100-567-81	CERAMIC CHIP 0.01uF 10% 25V
C6026	1-165-908-11	CERAMIC CHIP 1uF 10% 10V
C6027	1-125-777-11	CERAMIC CHIP 0.1uF 10% 10V
C6031	1-112-534-11	CERAMIC CHIP 10uF 20% 6.3V
C6032	1-127-895-91	TANTAL. CHIP 22uF 20% 4V
C6033	1-165-884-11	CERAMIC CHIP 2.2uF 10% 6.3V
C6034	1-125-777-11	CERAMIC CHIP 0.1uF 10% 10V
C6035	1-164-739-11	CERAMIC CHIP 560PF 5% 50V
C6037	1-125-777-11	CERAMIC CHIP 0.1uF 10% 10V
C6038	1-100-786-91	TANTAL. CHIP 22uF 20% 6.3V
C6039	1-100-567-81	CERAMIC CHIP 0.01uF 10% 25V
C6040	1-100-567-81	CERAMIC CHIP 0.01uF 10% 25V
C6041	1-100-567-81	CERAMIC CHIP 0.01uF 10% 25V
C6042	1-112-717-91	CERAMIC CHIP 1uF 10% 6.3V
C6043	1-112-717-91	CERAMIC CHIP 1uF 10% 6.3V
* C6044	1-112-746-11	CERAMIC CHIP 4.7uF 10% 6.3V
* C6045	1-112-746-11	CERAMIC CHIP 4.7uF 10% 6.3V
C6046	1-125-777-11	CERAMIC CHIP 0.1uF 10% 10V
		< CONNECTOR >
* CN4003	1-816-654-51	FFC/FPC CONNECTOR (LIF) 6P
CN4004	1-817-913-41	MEMORY STICK DUO CONNECTOR
* CN4005	1-821-196-11	CONNECTOR, FPC (ZIF) 39P
* CN4006	1-821-196-11	CONNECTOR, FPC (ZIF) 39P
* CN6007	1-817-543-71	CONNECTOR, FPC (ZIF) 27P
		< DIODE >
D4002	6-501-216-01	DIODE CL-271HR-C-TS (MS ACCESS)
* D6005	6-501-955-01	DIODE MAZS056G08S0
		< FERRITE BEAD >
FB4001	1-469-580-21	INDUCTOR, FERRITE BEAD (1005)
FB4002	1-469-580-21	INDUCTOR, FERRITE BEAD (1005)
FB4003	1-469-580-21	INDUCTOR, FERRITE BEAD (1005)
FB4004	1-469-580-21	INDUCTOR, FERRITE BEAD (1005)
		< IC >
IC6001	8-753-229-95	IC CXM3006CER-T4
		< COIL >
L6001	1-400-588-11	INDUCTOR 10uH
L6002	1-400-588-11	INDUCTOR 10uH
L6003	1-400-588-11	INDUCTOR 10uH
		< TRANSISTOR >
Q6001	8-729-427-37	TRANSISTOR XP411F-TXE
Q6002	8-729-427-67	TRANSISTOR XP421F-TXE
Q6010	6-550-601-01	TRANSISTOR UNRF2A300AS0
Q6011	6-551-184-01	TRANSISTOR MCH6305-TL-E-S
* Q6013	6-551-157-01	TRANSISTOR 2SA207900AS0

Ref. No.	Part No.	Description
Q6018	6-550-239-01	TRANSISTOR DTA144EMFS6T2L
Q6019	8-729-054-48	TRANSISTOR UP04601008S0
Q6020	8-729-054-48	TRANSISTOR UP04601008S0
		< RESISTOR >
R4001	1-218-990-81	SHORT CHIP 0
R4002	1-218-942-11	RES-CHIP 120 5% 1/16W
R4003	1-218-942-11	RES-CHIP 120 5% 1/16W
R4004	1-218-942-11	RES-CHIP 120 5% 1/16W
R4005	1-218-942-11	RES-CHIP 120 5% 1/16W
R4006	1-218-990-81	SHORT CHIP 0
R4007	1-218-990-81	SHORT CHIP 0
R4008	1-218-949-11	RES-CHIP 470 5% 1/16W
R6039	1-218-990-81	SHORT CHIP 0
R6041	1-218-977-11	RES-CHIP 100K 5% 1/16W
R6042	1-218-981-91	RES-CHIP 220K 5% 1/16W
R6043	1-218-978-11	RES-CHIP 120K 5% 1/16W
R6045	1-218-989-11	RES-CHIP 1M 5% 1/16W
R6061	1-218-975-11	RES-CHIP 68K 5% 1/16W
R6062	1-218-990-81	SHORT CHIP 0
R6064	1-208-934-11	METAL CHIP 91K 0.5% 1/16W
R6065	1-208-911-11	METAL CHIP 10K 0.5% 1/16W
R6066	1-218-990-81	SHORT CHIP 0
R6067	1-218-965-11	RES-CHIP 10K 5% 1/16W
R6068	1-218-990-81	SHORT CHIP 0
R6069	1-218-990-81	SHORT CHIP 0
R6070	1-218-990-81	SHORT CHIP 0
R6071	1-218-990-81	SHORT CHIP 0
R6072	1-218-990-81	SHORT CHIP 0
R6083	1-208-691-11	METAL CHIP 2.2K 0.5% 1/16W
R6084	1-208-695-11	METAL CHIP 3.3K 0.5% 1/16W
R6085	1-218-969-11	RES-CHIP 22K 5% 1/16W
R6086	1-208-643-11	METAL CHIP 22 0.5% 1/16W
R6087	1-218-961-11	RES-CHIP 4.7K 5% 1/16W
R6088	1-218-969-11	RES-CHIP 22K 5% 1/16W
R6089	1-218-967-11	RES-CHIP 15K 5% 1/16W
R6090	1-218-968-11	RES-CHIP 18K 5% 1/16W
		< SWITCH >
S4001	1-771-138-21	SWITCH, KEY BOARD (POWER)
		< VARISTOR >
* VDR401	1-802-279-11	VARISTOR (SMD)

Electrical parts list of the SE-174 board is not shown.
Page 5-18 is not shown.

Ref. No.	Part No.	Description
	A-1528-450-A	ST-186 BOARD, COMPLETE *****
< CAPACITOR >		
C5002	1-125-777-11	CERAMIC CHIP 0.1uF 10% 10V
C5003	1-165-884-11	CERAMIC CHIP 2.2uF 10% 6.3V
C5004	1-165-875-11	CERAMIC CHIP 10uF 10% 10V
C5005	1-163-001-11	CERAMIC CHIP 220PF 10% 50V
C7501	1-125-777-11	CERAMIC CHIP 0.1uF 10% 10V
< CONNECTOR >		
* CN7501	1-821-857-51	CONNECTOR, FPC (LIF (NON-ZIF))
* CN7503	1-820-031-51	CONNECTOR, FPC (LIF (NON-ZIF))
* CN7504	1-816-644-51	FFC/FPC CONNECTOR (LIF) 12P
* CN7505	1-816-655-51	FFC/FPC CONNECTOR (LIF) 8P
< DIODE >		
D5002	6-500-619-01	DIODE RB520S-40TE61
△D5003	6-501-096-01	DIODE CRF02 (TE85R)
< IC >		
△IC5001	6-707-554-01	IC TPS65552DGQR
< COIL >		
L5001	1-412-027-11	INDUCTOR 2.2uH
< TRANSISTOR >		
△* Q5001	6-551-937-01	TRANSISTOR TIG032TS-S-TL-E
< RESISTOR >		
R5002	1-216-864-11	SHORT CHIP 0
R5003	1-208-947-11	METAL CHIP 330K 0.5% 1/16W
R5004	1-208-935-11	METAL CHIP 100K 0.5% 1/16W
R5005	1-218-990-81	SHORT CHIP 0
R5008	1-216-065-91	RES-CHIP 4.7K 5% 1/10W
R5010	1-216-809-11	METAL CHIP 100 5% 1/10W
R5011	1-218-989-11	RES-CHIP 1M 5% 1/16W
R7501	1-216-295-91	SHORT CHIP 0
< TRANSFORMER >		
△T5001	1-443-568-31	TRANSFORMER, D.C.-D.C.CONVERTER

Electrical parts list of the VC-522 board is not shown.
Pages 5-20 to 5-23 are not shown.

• Refer to page 5-1 for mark △.

• **EXCEPT J MODEL**

Checking supplied accessories.

to **J MODEL**

Note: This item is supplied with the unit as an accessory, but is not prepared as a service part.

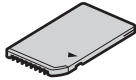

"Memory Stick PRO Duo" 4GB
(Note)

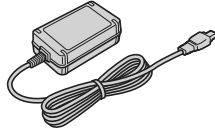

AC Adaptor
(AC-L200/L200B)
▲ 1-479-285-21

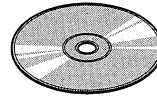

DVD-ROM
"ENJOY HANDYCAM"
3-282-264-01 (KR)
ENGLISH/KOREAN/JAPANESE
3-282-264-11 (US, CND)
ENGLISH/FRENCH/SPANISH/PORTUGUESE
3-282-264-21 (UK, NE)
ENGLISH/RUSSIAN/GERMAN/TURKISH
3-282-264-51 (AEP)
ENGLISH/FRENCH/GERMAN/DUTCH/SPANISH/
PORTUGUESE/ITALIAN/TURKISH
3-282-264-61 (E, HK, AUS, CH)
ENGLISH/FRENCH/SIMPLIFIED CHINESE for CHINA/
TRADITIONAL CHINESE for HONG KONG
3-282-264-71 (E)
ENGLISH/TRADITIONAL CHINESE for TAIWAN/
SPANISH/PORTUGUESE

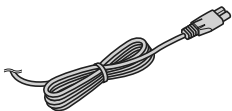

Power Cord
▲ 1-555-074-91 (AUS)
▲ 1-790-107-61 (US, CND)
▲ 1-792-549-41 (JE)
▲ 1-824-910-71 (AEP, NE, E: PAL)
▲ 1-827-269-12 (UK, HK)
▲ 1-832-121-31 (CH)
▲ 1-833-892-21 (KR)
▲ 1-834-852-11 (E: NTSC)



Conversion (2P) Adaptor
▲ 1-569-007-12
(E: NTSC, JE)



21-pin Adaptor
1-770-783-21
(AEP, UK, NE)

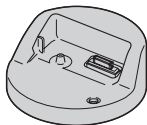

Handycam Station
(DCRA-C230)
1-821-803-11

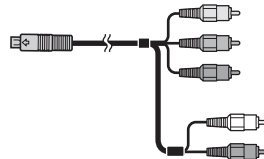

Component A/V Cable
1-834-647-11



A/V Connecting Cable
1-823-156-51

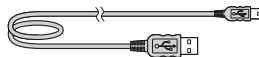

USB Cable (Long)
1-829-868-31

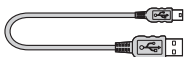

USB Cable (Short)
(not supplied)

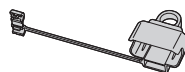

USB Adaptor Cap
(not supplied)



Dedicated USB Terminal Adaptor
(not supplied)

USB Adaptor Assy
A-1539-779-A

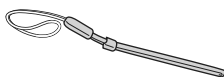

Wrist Strap
3-299-909-01

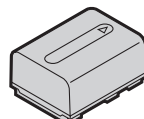

Rechargeable Battery Pack
NP-FH50
(Note)

• Refer to page 5-1 for mark ▲.

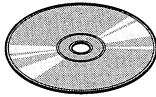

CD-ROM
 "Handycam Application Software"
 ("Picture Motion Browser (Software)"/
 "PMB Guide")/
 "Handycam Handbook (PDF)"
 3-288-517-02



Handycam Handbook (PDF)

The CD-ROM supplied contains all of language version of the Handycam Handbook (PDF) for printing.

- The printed matter is not supplied. If required, please order it with the part number below.
- (Only for destination Japanese model)
日本国内については日本語のみが印刷での部品供給可能です。

HDR-TG1

- * 3-288-518-01 (JAPANESE)
- * 3-288-518-11 (ENGLISH)
- * 3-288-518-21 (FRENCH)
- * 3-288-518-31 (SPANISH)
- * 3-288-518-41 (PORTUGUESE)
- * 3-288-518-51 (TRADITIONAL CHINESE)
- * 3-288-518-61 (KOREAN)

HDR-TG1E/TG3E

- * 3-288-519-11 (ENGLISH)
- * 3-288-519-21 (FRENCH)
- * 3-288-519-31 (DUTCH)
- * 3-288-519-41 (GREEK)
- * 3-288-519-51 (GERMAN)
- * 3-288-519-61 (ITALIAN)
- * 3-288-519-71 (TURKISH)
- * 3-288-519-81 (SPANISH)
- * 3-288-519-91 (PORTUGUESE)
- * 3-288-520-11 (POLISH)
- * 3-288-520-21 (CZECH)
- * 3-288-520-31 (HUNGARIAN)
- * 3-288-520-41 (SLOVAK)
- * 3-288-520-51 (RUSSIAN)
- * 3-288-520-61 (UKRAINIAN)
- * 3-288-520-71 (SWEDISH)
- * 3-288-520-81 (DANISH)
- * 3-288-520-91 (FINNISH)
- * 3-288-521-11 (SIMPLIFIED CHINESE)
- * 3-288-521-21 (ARABIC)
- * 3-288-521-31 (PERSIAN)
- * 3-288-521-41 (MALAY)
- * 3-288-521-51 (THAI)
- * 3-288-521-61 (INDONESIAN)
- * 3-288-521-71 (TRADITIONAL CHINESE)



Operating Guide

HDR-TG1

- 3-288-522-11 (ENGLISH, SPANISH) (US, CND, E, JE)
- 3-288-522-21 (FRENCH) (CND)
- 3-288-522-31 (PORTUGUESE) (JE)
- 3-288-522-41 (TRADITIONAL CHINESE) (E)
- 3-288-522-51 (KOREAN) (KR, JE)

HDR-TG1E/TG3E

- 3-288-523-11 (ENGLISH) (AEP, UK, E, HK, AUS, JE)
- 3-288-523-21 (FRENCH, DUTCH, GREEK) (AEP)
- 3-288-523-31 (GERMAN, ITALIAN, TURKISH) (AEP)
- 3-288-523-41 (SPANISH, PORTUGUESE, POLISH) (AEP)
- 3-288-523-51 (CZECH, HUNGARIAN, SLOVAK) (AEP)
- 3-288-523-61 (RUSSIAN, UKRAINIAN) (NE, JE)
- 3-288-523-71 (SWEDISH, DANISH, FINNISH) (NE)
- 3-288-523-81 (SIMPLIFIED CHINESE) (E, CH, JE)
- 3-288-523-91 (ARABIC, PERSIAN) (E)
- 3-288-524-41 (TRADITIONAL CHINESE) (HK)

● J MODEL

付属品

Note：当商品はアクセサリとして同梱されておりますがサービス用補修部品としては準備しておりません。

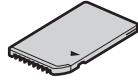

"メモリスティックPROデュオ"
8GB
(Note)

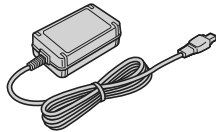

ACアダプター
(AC-L200/L200B)
△ 1-479-285-21

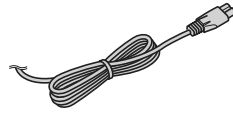

電源コード
△ 1-792-549-41

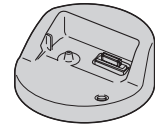

ハンディカムステーション
(DCRA-C230)
1-821-803-11

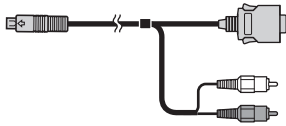

D端子A/Vケーブル
1-834-646-21



A/V接続ケーブル
1-823-156-51

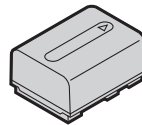

リチャージャブルバッテリーパック
NP-FH50
(Note)

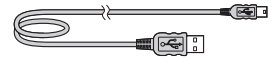

USBケーブル (長)
1-829-868-31

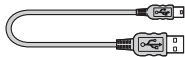

USBケーブル (短)
(供給せず)



USBアダプターキャップ
(供給せず)

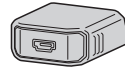

専用USB端子アダプター
(供給せず)

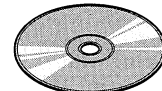

DVD-ROM
「エンジョイハンディーカム」
3-282-264-01
英語/韓国語/日本語

USBアダプタ組立
A-1539-779-A

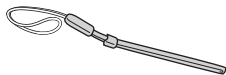

リストストラップ
3-299-909-01



取扱説明書
3-288-522-01 (日本語)

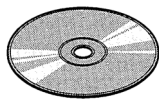

CD-ROM
「Handycam Application Software」
(「Picture Motion Browser」(ソフトウェア)/
「PMBガイド」/
「ハンディカムハンドブック」(PDF))
3-288-517-02



ハンディカムハンドブック (PDF)

印刷用のハンディカムハンドブック (PDF) は
全ての言語が付属品のCD-ROMに含まれています。
・印刷物は付属されておりません。
必要な場合は下記部品番号にて注文となります。

* 3-288-518-01 (日本語)

● △マークについては、5-1ページを参照して下さい。

HDR-TG1/TG1E/TG3E

SONY®

SERVICE MANUAL

Ver. 1.1 2008.08

LEVEL 2

US Model
 Canadian Model
 AEP Model
 UK Model
 North European Model
 E Model
 Australian Model
 Hong Kong Model
 Chinese Model
 Korea Model
 Tourist Model
 Japanese Model

SUPPLEMENT-1

File this supplement with the service manual.
 (DI08-212)

- Change of Repair Parts

 : Points added portion.

5. REPAIR PARTS LIST

5-1. EXPLODED VIEWS

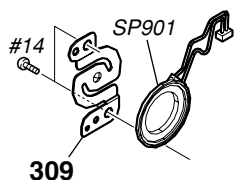
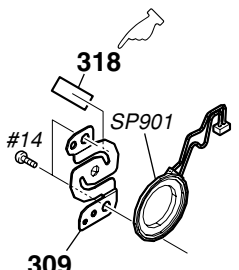
Page	Former	New												
5-8														
	<table border="1"> <thead> <tr> <th>Ref. No.</th> <th>Part No.</th> <th>Description</th> </tr> </thead> <tbody> <tr> <td> </td> <td> </td> <td> </td> </tr> </tbody> </table>	Ref. No.	Part No.	Description				<table border="1"> <thead> <tr> <th>Ref. No.</th> <th>Part No.</th> <th>Description</th> </tr> </thead> <tbody> <tr> <td>* 318</td> <td>4-111-090-01</td> <td>SHEET SP</td> </tr> </tbody> </table>	Ref. No.	Part No.	Description	* 318	4-111-090-01	SHEET SP
Ref. No.	Part No.	Description												
Ref. No.	Part No.	Description												
* 318	4-111-090-01	SHEET SP												

HDR-TG1/TG1E/TG3E

SONY®

LEVEL 2

SERVICE MANUAL

Ver. 1.3 2009.06

US Model
Canadian Model
AEP Model
UK Model
North European Model
E Model
Australian Model
Hong Kong Model
Chinese Model
Korea Model
Tourist Model
Japanese Model

SUPPLEMENT-2

File this supplement with the service manual.
(09-062)

• Change of Repair Parts

 : Points changed portion.

4. PRINTED WIRING BOARDS AND SCHEMATIC DIAGRAMS

4-2. SCHEMATIC DIAGRAMS

MS-396 BOARD (2/2) (CONNECTOR)

(Service manual page 4-32, Location F-6 to G-7)

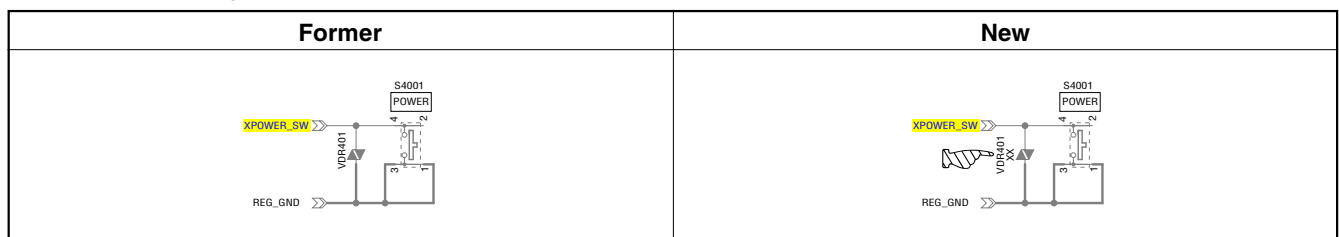

- : Points added portion.
- : Points changed portion.

ST-186 BOARD (2/2) (CONNECTOR)
 (Service manual page 4-37, Location B-2 to B-3)

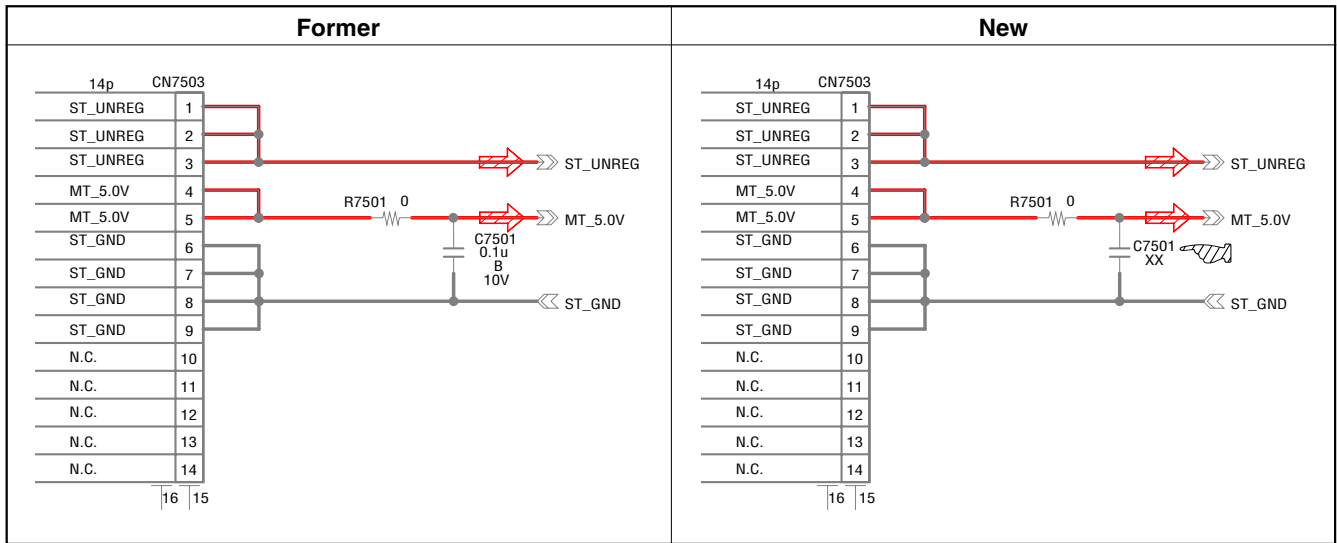

5. REPAIR PARTS LIST

5-1. EXPLODED VIEWS

Page	Former	New												
5-3														
	<table border="1" style="width: 100%; border-collapse: collapse;"> <thead> <tr> <th style="width: 15%;">Ref. No.</th> <th style="width: 15%;">Part No.</th> <th style="width: 70%;">Description</th> </tr> </thead> <tbody> <tr> <td> </td> <td> </td> <td> </td> </tr> </tbody> </table>	Ref. No.	Part No.	Description				<table border="1" style="width: 100%; border-collapse: collapse;"> <thead> <tr> <th style="width: 15%;">Ref. No.</th> <th style="width: 15%;">Part No.</th> <th style="width: 70%;">Description</th> </tr> </thead> <tbody> <tr> <td>* 60</td> <td>3-300-053-01</td> <td>SHEET, CAPACITOR</td> </tr> </tbody> </table>	Ref. No.	Part No.	Description	* 60	3-300-053-01	SHEET, CAPACITOR
Ref. No.	Part No.	Description												
Ref. No.	Part No.	Description												
* 60	3-300-053-01	SHEET, CAPACITOR												

5-2. ELECTRICAL PARTS LIST

Page	Former	New																					
5-17	<table border="1" style="width: 100%; border-collapse: collapse;"> <thead> <tr> <th style="width: 15%;">Ref. No.</th> <th style="width: 15%;">Part No.</th> <th style="width: 70%;">Description</th> </tr> </thead> <tbody> <tr> <td colspan="3">MS-396 Board</td> </tr> <tr> <td colspan="3" style="text-align: center;">< VARISTOR ></td> </tr> <tr> <td>* VDR401</td> <td>1-802-279-11</td> <td>VARISTOR (SMD)</td> </tr> </tbody> </table>	Ref. No.	Part No.	Description	MS-396 Board			< VARISTOR >			* VDR401	1-802-279-11	VARISTOR (SMD)	<table border="1" style="width: 100%; border-collapse: collapse;"> <thead> <tr> <th style="width: 15%;">Ref. No.</th> <th style="width: 15%;">Part No.</th> <th style="width: 70%;">Description</th> </tr> </thead> <tbody> <tr> <td colspan="3">MS-396 Board</td> </tr> <tr> <td colspan="3" style="text-align: center;">< VARISTOR ></td> </tr> </tbody> </table>	Ref. No.	Part No.	Description	MS-396 Board			< VARISTOR >		
Ref. No.	Part No.	Description																					
MS-396 Board																							
< VARISTOR >																							
* VDR401	1-802-279-11	VARISTOR (SMD)																					
Ref. No.	Part No.	Description																					
MS-396 Board																							
< VARISTOR >																							
5-19	<table border="1" style="width: 100%; border-collapse: collapse;"> <thead> <tr> <th style="width: 15%;">Ref. No.</th> <th style="width: 15%;">Part No.</th> <th style="width: 70%;">Description</th> </tr> </thead> <tbody> <tr> <td colspan="3">ST-186 Board</td> </tr> <tr> <td colspan="3" style="text-align: center;">< CAPACITOR ></td> </tr> <tr> <td>C7501</td> <td>1-125-777-11</td> <td>CERAMIC CHIP 0.1uF 10% 10V</td> </tr> </tbody> </table>	Ref. No.	Part No.	Description	ST-186 Board			< CAPACITOR >			C7501	1-125-777-11	CERAMIC CHIP 0.1uF 10% 10V	<table border="1" style="width: 100%; border-collapse: collapse;"> <thead> <tr> <th style="width: 15%;">Ref. No.</th> <th style="width: 15%;">Part No.</th> <th style="width: 70%;">Description</th> </tr> </thead> <tbody> <tr> <td colspan="3">ST-186 Board</td> </tr> <tr> <td colspan="3" style="text-align: center;">< CAPACITOR ></td> </tr> </tbody> </table>	Ref. No.	Part No.	Description	ST-186 Board			< CAPACITOR >		
Ref. No.	Part No.	Description																					
ST-186 Board																							
< CAPACITOR >																							
C7501	1-125-777-11	CERAMIC CHIP 0.1uF 10% 10V																					
Ref. No.	Part No.	Description																					
ST-186 Board																							
< CAPACITOR >																							

HARDWARE LIST (1/7)

#1: M1.7 X 2.5
(Black)
2-635-562-11

#2: M1.7 X 4.0
(Black)
2-635-562-31

#3: M1.7 X 2.5
(Red)
2-660-401-01

#4: M1.4 X 2.5 (Tapping)
(Dark Silver)
3-348-998-81

#5: M1.7 X 3.5 (Tapping)
(Black)
3-080-204-01

#6: M1.4 X 1.7
(Silver)
2-598-474-01

#7: M1.7 X 1.6
(Black)
7-627-552-18

#8: M1.7 X 3.5 (Tapping)
(Silver)
3-078-890-01

#9: M1.7 X 5.0 (Tapping)
(Silver)
3-078-890-21

#10: M1.7 X 4.0
(Silver)
2-599-475-31

#11: M1.7 X 4.0 (Tapping)
(Silver)
3-078-890-11

#12: M1.7 X 5.0 (Tapping)
(Black)
3-080-204-21

#13: M1.7 X 2.5 (Tapping)
(Silver)
3-085-397-01

#14: M1.7 X 2.5
(Silver)
2-599-475-11

#15: M1.4 X 1.5
(Silver)
3-062-214-01

#16: M1.4 X 2.5
(Silver)
2-586-337-01

#17: M1.7 X 1.5
(Silver)
2-586-389-01

#18: M1.4 X 2.5
(Silver)
2-635-591-21

#19: M1.2 X 4.0 (Tapping)
(Red)
3-086-156-21

#20: M1.4 X 3.0
(Silver)
2-635-591-31

HARDWARE LIST (2/7)

#21: M1.4 X 3.0
(Black)
2-662-396-21

#22: M1.7 X 5.0 (Tapping)
(Silver)
3-083-261-01

#23: M1.7 X 4.0 (Tapping)
(Black)
3-080-204-11

#24: B1.7 X 5.5 (Tapping)
(Black)
4-679-805-11

#25: M1.7 X 3.0
(Black)
2-635-562-21

#26: M1.4 X 2.0
(Silver)
2-635-591-11

#27: M1.4 X 2.0
(Black)
2-662-396-11

#28: M1.4 X 4.0 (Tapping)
(Silver)
3-348-998-61

#29: M1.4 X 2.5
(Black)
2-662-396-01

#30: M1.2 X 3.5 (Tapping)
(White)
3-086-156-11

#31: M3.0 X 4.0
(Silver)
2-102-434-01

#32: M2.0 X 4.5 (Tapping)
(Silver)
2-102-498-01

#33: M3.0 X 6.0
(Silver)
3-077-331-21

#34: M3.0 X 8.0
(Black)
3-077-331-41

#35: M4.0 X 6.0 (Tapping)
(Silver)
3-975-291-02

#36: M3.0 X 6.0
(Silver)
4-886-821-11

#37: M2.0 X 6.0 (Tapping)
(Black)
3-080-206-31

#38: M3.0 X 20.0 (Tapping)
(Silver)
7-685-651-79

#39: M2.6 X 5.0 (Tapping)
(Black)
7-685-791-09

#40: M2.0 X 4.0 (Tapping)
(Silver)
7-685-851-04

HARDWARE LIST (3/7)

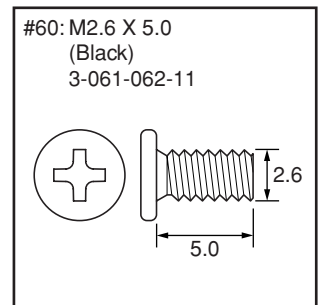
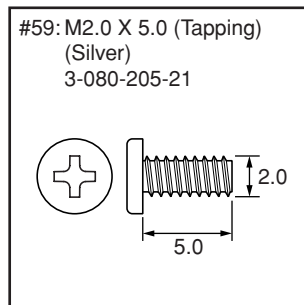
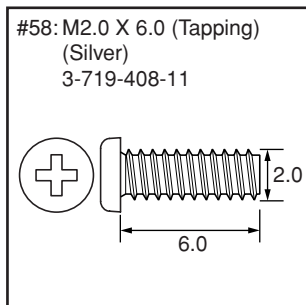
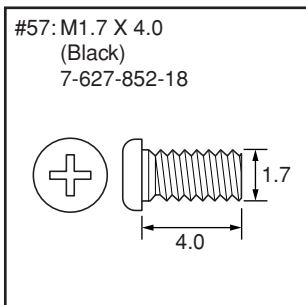
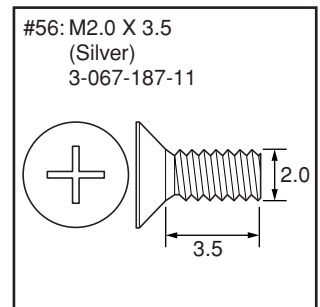
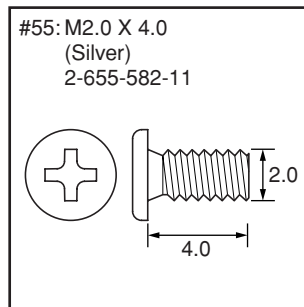
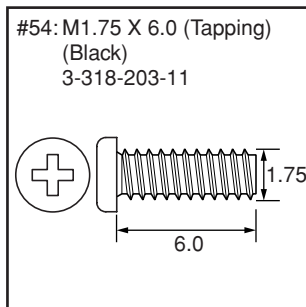
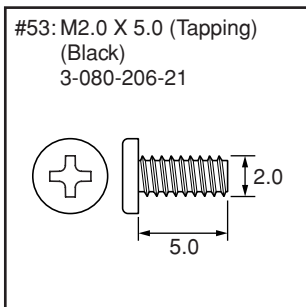
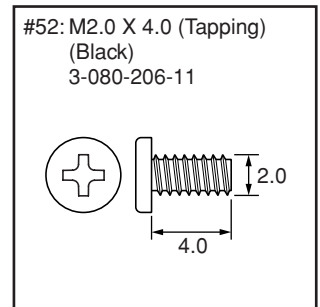
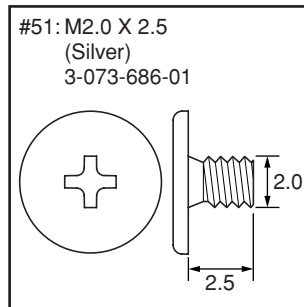
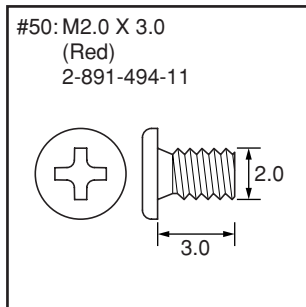
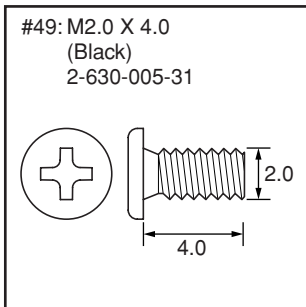
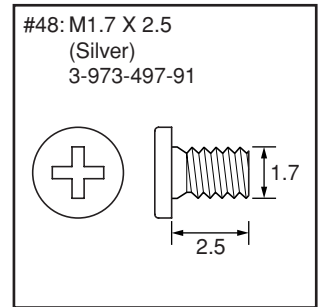
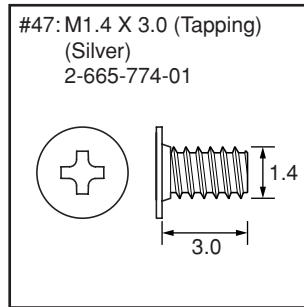
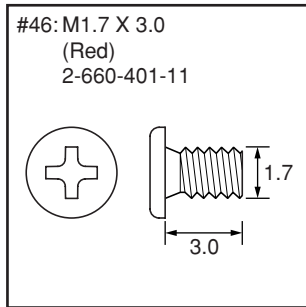
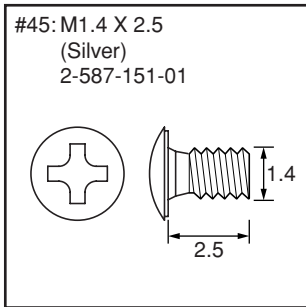
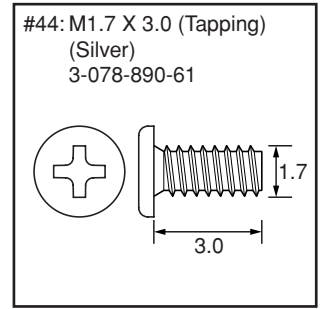
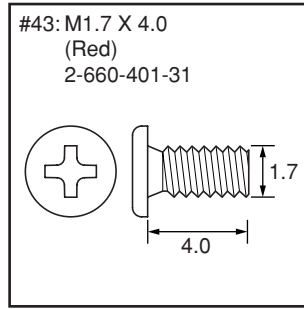
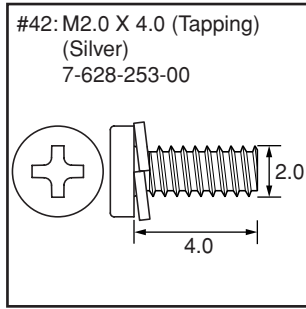
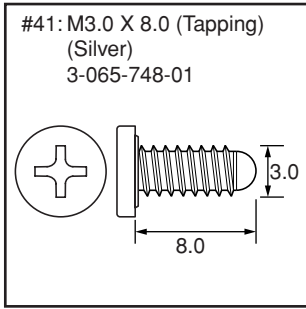

HARDWARE LIST (4/7)

#61: M3.0 X 10.0
(Black)
7-682-549-09

#62: M2.0 X 3.0
(Silver)
3-080-202-21

#63: M5.0 X 12.5
(Black)
3-060-811-21

#64: M1.7 X 5.0 (Tapping)
(Silver)
2-666-551-21

#65: M1.4 X 3.5
(Silver)
2-635-591-01

#66: M1.4 X 1.4
(Silver)
2-635-591-41

#67: M1.4 X 2.0
(Silver)
3-389-523-16

#68: M1.7 X 4.0
(Silver)
2-655-581-01

#69: M1.7 X 3.0
(Silver)
2-599-475-21

#70: M1.7 X 5.0
(Silver)
2-599-475-41

#71: M1.4 X 2.0
(Red)
3-208-537-01

#72: M1.4 X 2.0
(Silver)
4-663-621-41

#73: M1.2 X 4.0 (Tapping)
(Black)
3-086-156-61

#74: M1.7 X 6.0 (Tapping)
(Silver)
2-666-551-31

#75: M1.7 X 3.5 (Tapping)
(Silver)
2-666-551-01

#76: M1.7 X 4.0 (Tapping)
(Silver)
2-666-551-11

#77: M1.2 X 5.0 (Tapping)
(Silver)
3-086-156-31

#78: M1.4 X 3.5
(Red)
3-208-537-11

#79: M1.4 X 2.0
(Silver)
2-587-151-11

#80: M1.4 X 2.0
(Black)
3-279-411-01

HARDWARE LIST (5/7)

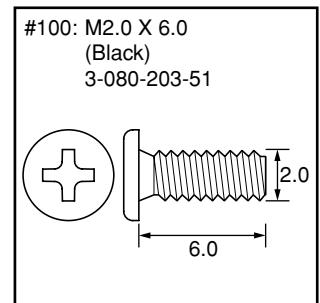
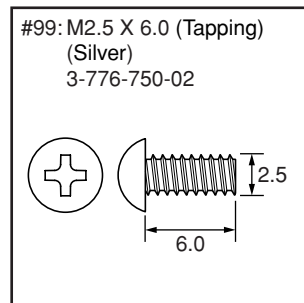
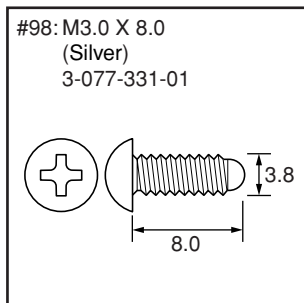
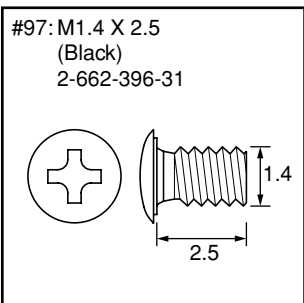
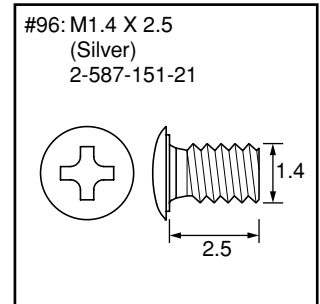
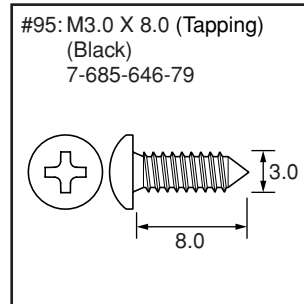
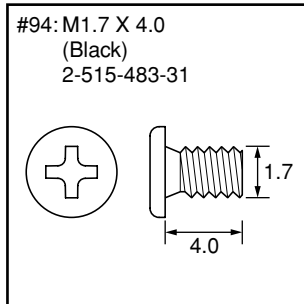
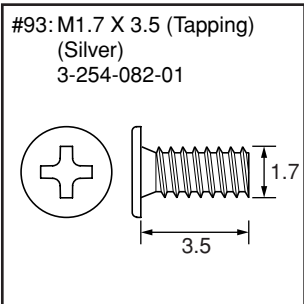
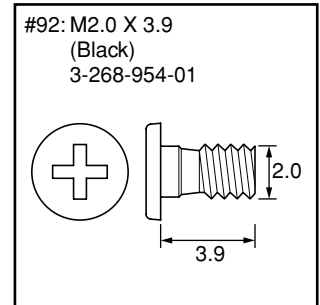
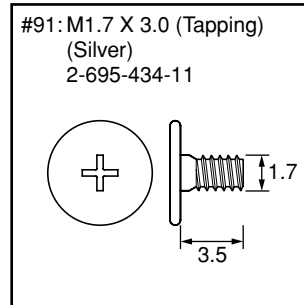
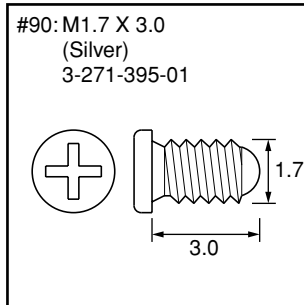
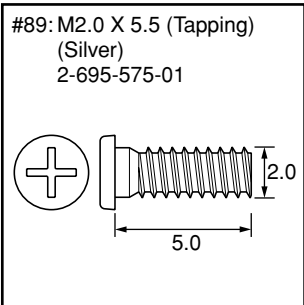
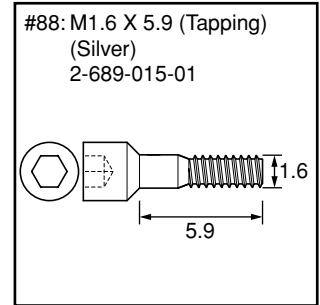
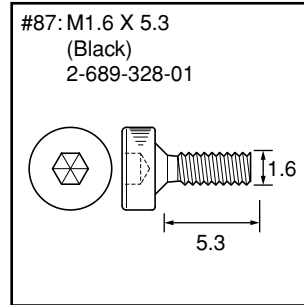
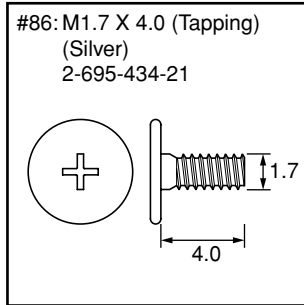
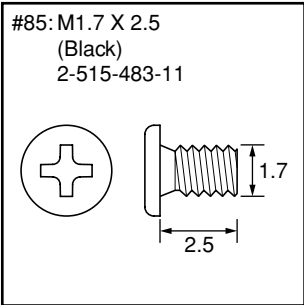
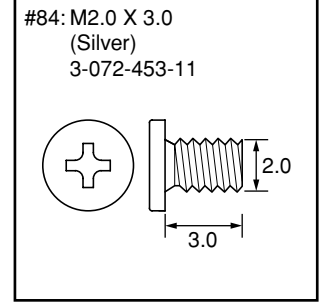
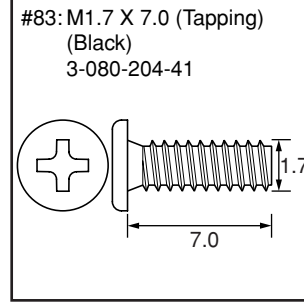
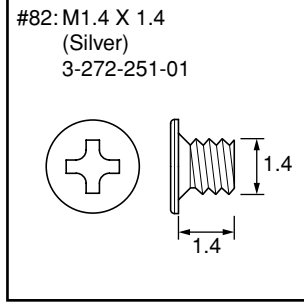
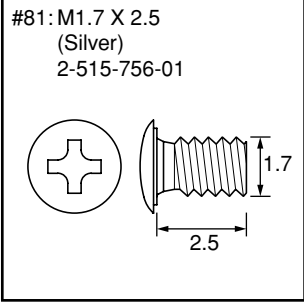

HARDWARE LIST (6/7)

#101: M2.0 X 5.0
(Silver)
7-621-555-39

#102: M2.6 X 8.0
(Black)
7-621-284-30

#103: M2.6 X 10.0
(Silver)
7-685-794-09

#104: M3.0 X 8.0
(Black)
7-682-548-09

#105: M2.0 X 4.0
(Red)
2-891-494-31

#106: M2.0 X 6.0
(Black)
3-713-786-11

#107: M2.0 X 5.0
(Silver)
3-032-750-01

#108: M1.7 X 3.0 (Tapping)
(Black)
2-695-430-01

#109: M1.7 X 3.0
(Black)
2-515-483-21

#110: M2.0 X 3.0
(Black)
2-630-005-21

#111: M1.7 X 4.0 (Tapping)
(Black)
2-887-124-01

#112: M1.4 X 5.0
(Black)
2-178-410-11

#113: M1.7 X 5.0
(Black)
2-635-562-41

#114: M2.0 X 5.5 (Tapping)
(Silver)
2-698-464-01

#115: M1.4 X 3.5 (Tapping)
(Silver)
3-348-998-51

#116: M2.0 X 3.5 (Tapping)
(Silver)
2-695-435-01

#117: M1.7 X 4.5 (Tapping)
(Silver)
2-695-429-31

#118: M1.4 X 2.0
(Black)
2-655-580-01

#119: M2.6 X 5.0
(Black)
7-627-556-58

#120: M2.6 X 6.0
(Silver)
7-621-770-67

HARDWARE LIST (7/7)

#121: M2.0 X 4.0 (Tapping)
(Silver)
3-080-205-11

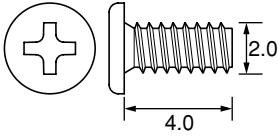

#122: M3.0 X 6.0
(Black)
7-682-547-09

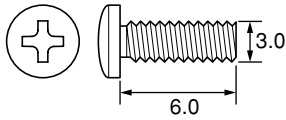

#123: M4.0 X 8.0
(Black)
7-682-561-09

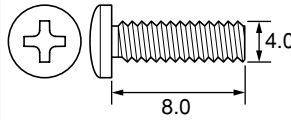

#124: M1.7 X 2.0
(Silver)
2-599-475-01

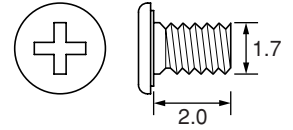

#125: M1.4 X 3.0
(Black)
3-291-847-01

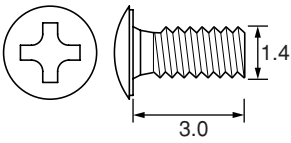

#126: M2.9 X 3.5
(Black)
3-292-616-01

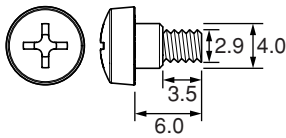

#127: M3.0 X 25.0
(Black)
7-682-654-09

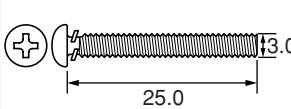

#128: M4.0 X 12.0
(Black)
3-452-472-01

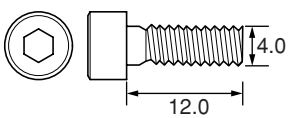

#129: M3.0 X 12.0
(Black)
7-682-550-09

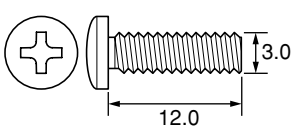

#130: M2.0 X 4.5 (Tapping)
(Silver)
3-732-817-11

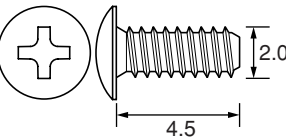

#131: M4.0 X 12.0
(Silver)
3-452-471-01

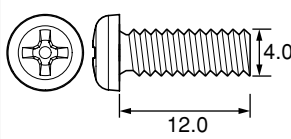

#132: M2.6 X 6.0
(Black)
4-673-655-01

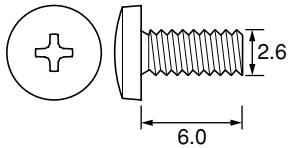

#133: M3.0 X 6.0
(Black)
3-452-484-01

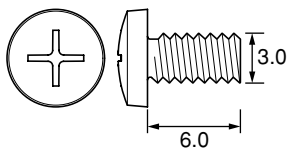

#134: M2.6 X 7.0
(Black)
3-299-572-01

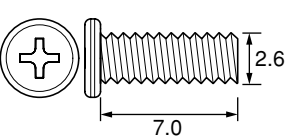

#135: M2.0 X 2.5
(Black)
7-627-553-28

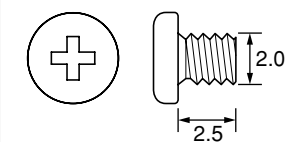

#136: M1.4 X 4.0 (Tapping)
(Black)
3-065-509-11

